

ITS-6500-MV

Integrated Transformer Station for 1500V Utility PV Plant (For SP-275K-H1 String inverter)

Safety

- MV and LV isolated, with independent control room
- Integrated smoke sensing alarm
- LV copper busbar fully enclosed protection design

Low system cost

- Convenient for large block size PV plant
- Integrated MV transformer and switchgear

High reliability

- Suitable for all kinds of harsh environments
- All device compliance with international standards

Easy O&M

- Integrated current and voltage monitoring function for online analysis and trouble shooting



Circuit Diagram

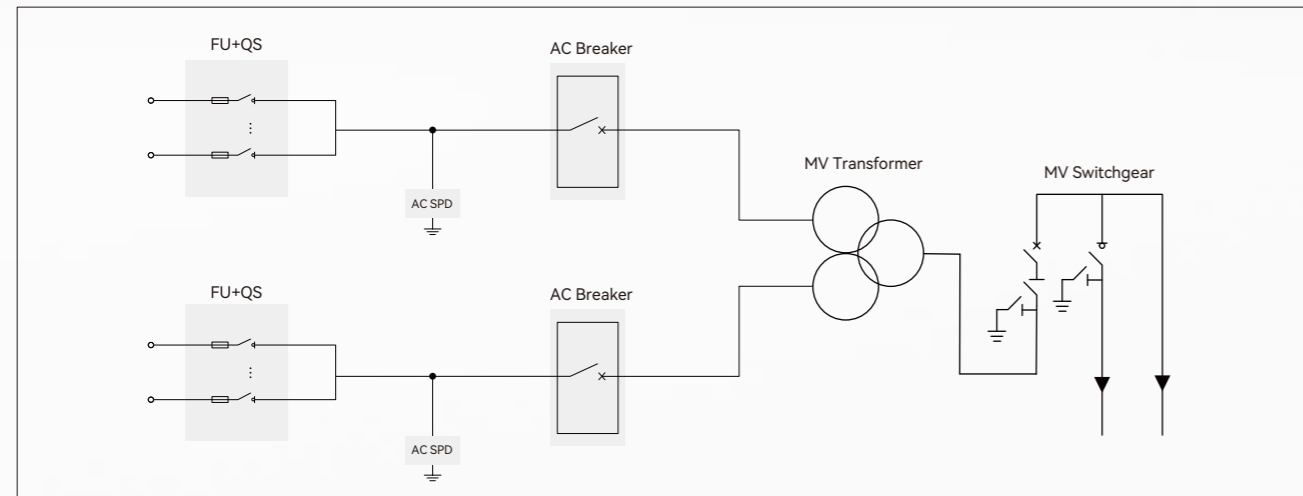

Model		ITS-6500-MV
Input		
AC power	6500kVA@45°C/7150kVA@30°C	
Max. Inverters Quality	26	
Rated Input voltage	800V	
Main switch specification	3200A/800Vac/3P, 2pcs	
Disconnecter specification	260A/800Vac/3P, 26pcs	
Fuse specification	350A/800Vac/1P, 78pcs	
Output		
Rated AC output Voltage	10-35kV	
Transformer Type	Oil-immersed	
Transformer Vector Group	Dy11y11	
Rated grid frequency/range	50Hz/45~55Hz, 60Hz/55~65Hz	
Transformer Tappings	±2x2.5%	
Impedance	8% (±10%)	
MV Switchgear Type	SF6 Gas Insulated, 3 feeders	
Protection		
AC input protection	Fuse+disconnecter	
Transformer protection	Oil-temperature, Oil-level, Oil-pressure and Buchholz	
AC MV output protection	Circuit breaker	
LV Over voltage protection	Type II (Optional: Type I+II)	
MV Relay Protection	50/51, 50N/51N, (Optional: 50G/51G)	
Internal arcing fault	IAC AFL 20kA/1s	
General Data		
Auxiliary power supply	Standard: 5kVA, Optional: Max. 40kVA	
Degree of protection	IP54	
Temperature	-30°C~+60°C	
Allowed humidity (non condensing)	0~95%	
Transformer Cooling mode	ONAN (Oil Natural Air Natural)	
Max. operating altitude	2000m(standard) />2000m (Optional)	
Communication port	RS485/Ethernet	
Certificates (more available on request)	IEC 60076, IEC 62271, IEC 61439	
Dimensions (W×H×D)	6058x2896x2438mm	
Weight	22T	