

# SN3.0/3.68/4.0/5.0/6.0HS

## Single Phase Hybrid Inverter/2 MPPTs

### Features

- 85~460V Wide battery voltage range
- Built-in multiple operating modes
- Switch time to EPS mode within 10ms
- Extra load capacity under EPS mode
- DC/AC ratio up to 1.5
- Built-in arc-fault circuit-Interrupter
- Fanless & silent design
- Intelligent monitoring & maintenance



### Circuit Diagram

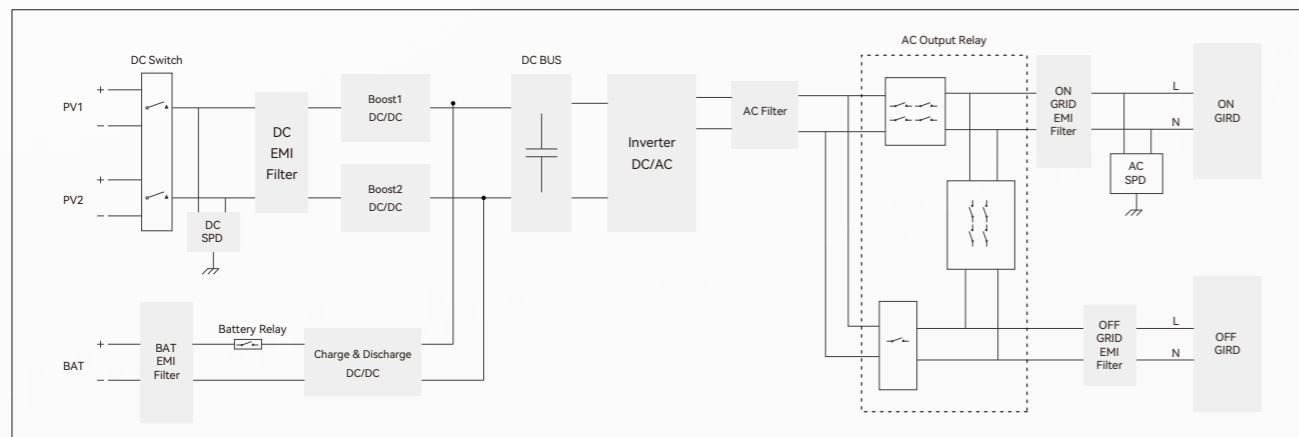

Model	SN3.0HS	SN3.68HS	SN4.0HS	SN5.0HS	SN6.0HS
<b>Input (PV)</b>					
Recommended max. PV power (STC)	4500Wp	5520Wp	6000Wp	7500Wp	9000Wp
Max. PV input voltage	600V				
Startup voltage	100V				
Nominal PV input voltage	360V				
MPPT operating voltage range	90V~560V				
Number of PV inputs	2 (2MPPTs, 1/1)				
Max. input current per MPPT	16A				
Max. short circuit current per MPPT	25A				
<b>Battery parameter</b>					
Battery type	Li-ion				
Battery voltage range	85V~460V				
Max. charge/discharge current	25A/25A				
Max. charge/discharge power	3000W/3000W	3680W/3680W	4000W/4000W	5000W/5000W	6000W/6000W
<b>Grid input/output</b>					
Nominal grid output power	3000W	3680W	4000W	5000W	6000W
Max. grid output power	3000VA	3680VA	4000VA	5000VA	6000VA
Max. grid output current	13A	16A	17.4A	21.7A	26.1A
Max. input power from grid	6000VA	7300VA	8000VA	10000VA	12000VA
Max. input current from grid	26A	32A	34.8A	43.4A	52.3A
Nominal grid voltage	L/N/PE, 230V				
Nominal grid frequency	50/60Hz				
Harmonic(THD)	<3%				
Power factor range	0.8leading~0.8lagging				
<b>Back-up data</b>					
Rated output power	3000W	3680W	4000W	5000W	6000W
Peak output power	5000VA, 10s	5000VA, 10S	5000VA, 10s	7500VA, 10s	7500VA, 10s
Back up switch time	10ms				
Nominal output voltage	230V				
Nominal output frequency	50/60Hz				
<b>Efficiency</b>					
Max. efficiency	97.60%				
EU efficiency	97.00%				
<b>Protection</b>					
Anti islanding protection	Yes				
Leakage current protection	Yes				
PV reverse protection	Yes				
Short circuit protection	Yes				
Arc-fault circuit-interrupter	Yes				
RSD	Optional				
Surge protection	DC II/AC II				
Battery reverse protection	Yes				
<b>General data</b>					
Dimensions (W*H*D)	470*375*178mm				
Weight	16.8kg			17.2kg	
Installation method	Wall-mounted				
Topology	Transformerless				
Protection degree	IP65				
Operating temperature	-25 ~ 60°C				
Humidity	0 ~ 100%				
Cooling method	Natural				
Max. operating altitude	4000m (>3000m derating)				
Display	LED+APP				
Communication method	Wifi/4G/Ethernet,RS485,CAN				

IEC 62109-1/2, IEC61000-6,IEC61000-3, IEC62116, IEC61727, IEC61683, IEC60068, IEC61000-3, EN50549-1, IEC/EN62477, C10/11, CEI-0-21, NRS097-2, AS4777-2  
RD1699/UNE217001/UNE206007/NTS Type A, ORDINANCE No.140

© 2024 SINENG ELECTRIC CO., LTD. ALL RIGHTS RESERVED. SUBJECT TO CHANGE WITHOUT NOTICE.