

EP-3125-HC-UD/10~35, EP-3400-HA-UD/10~35

MV Turnkey Solution for 1500V Utility PV Plant

More power generation

- Inverter Max. efficiency 99%, Euro efficiency 98.7%
- 1500Vdc PV system reduce power loss
- High DC/AC ratio up to 1.8

Low system cost

- Convenient for large block size PV plant
- Integrated MV transformer and switchgear
- Night SVG function optional

High reliability

- Capacitor life prediction technology
- Key components at front side, easy for maintenance
- Current sensor for each DC input, more reliable for monitoring and control

Grid friendly

- Adjustable reactive power
- Low harmonics and fast response for grid regulation



Circuit Diagram

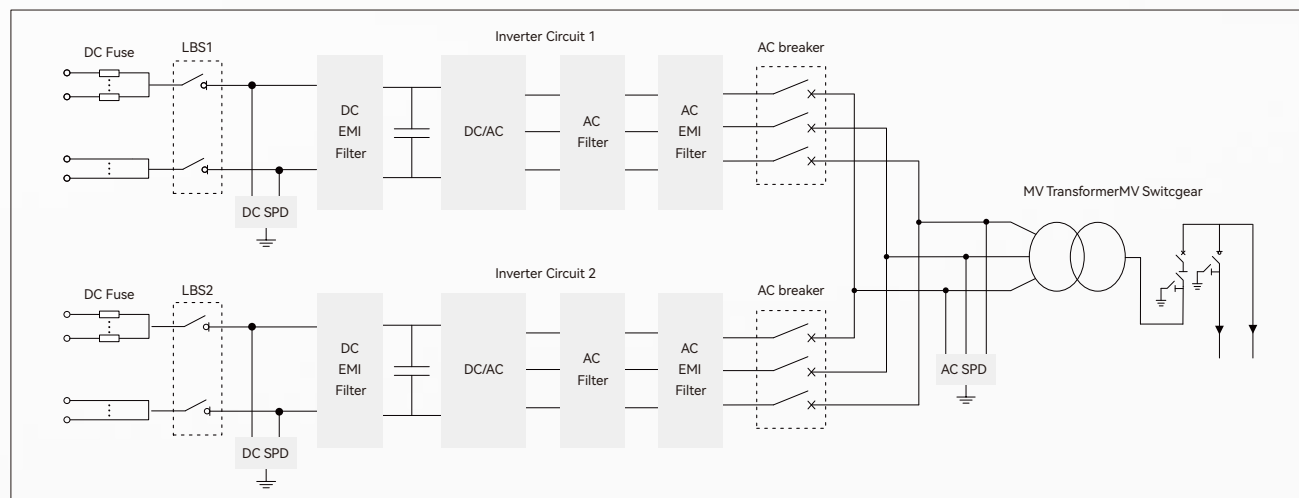

Model	EP-3125-HC-UD/10~35	EP-3400-HA-UD/10~35
Input (DC)		
Max. PV input voltage	1500V	
Max. input current	4191A	4075A
MPP voltage range for nominal power	875~1300V	900~1300V
Number of MPPT trackers	2	
Max. Number of DC inputs	22	
Output (AC)		
AC output power	3125kVA@50°C/3594kVA@25°C	3400kVA@45°C/3594kVA@25°C
AC voltage range	10~35kV	
Rated grid frequency/range	50 Hz/45~55 Hz, 60Hz/55~65 Hz	
Output current harmonic (at nominal power)	<3%	
DC current injection	<0.5% I _n	
Power factor at nominal power/range	>0.99/0.8 lagging to 0.8 leading	
Protection		
DC input protection	Load break switch+fuse	
AC output protection	Circuit breaker	
AC MV output protection	Circuit breaker	
Overvoltage protection	DC Type II/AC Type II	
Leakage current monitoring	Yes	
Grid monitoring/Ground fault monitoring	Yes/Yes	
Insulation monitoring	Yes	
Overheat protection	Yes	
Night SVG function	Optional	
Anti-PID function	Optional	
Efficiency		
Inverter max. efficiency	99.0%	
Inverter EU efficiency	98.7%	
Transformer		
Transformer rated power	3125kVA	3400kVA
Transformer max. power	3594kVA	3594kVA
LV/MV Voltage	0.6/10~35kV	0.63/10~35kV
Transformer Vector	Dy11	
Transformer cooling type	ONAN (Oil Natural Air Natural)	
General Data		
Auxiliary power supply	Standard: 5kVA, Optional: max. 40kVA	
Protection level	Inverter: IP65, Others: IP54	
Temperature	-30 ~ + 60°C	
Allowed humidity (non condensing)	0~95%	
Cooling method	Temperature controlled forced air cooling	
Max. operating altitude	2000m (standard) />2000m (optional)	
Display	Touch screen	
Communication port	RS485/Ethernet, Optional: optical fiber	
Certificates and approvals (more available on request)	CE, IEC 62109, IEC 61727, IEC 61683, IEC 62116, IEC 60068, IEC61000, IEC60076, IEC62271	
Dimensions (W×H×D)	6058×2896×2438mm	
Weight	18t	