



- ✓ *SN20HT*
- ✓ *SN25HT*
- ✓ *SN29.9HT*
- ✓ *SN30HT*
- ✓ *SN33HT*

User Manual

SN20-33HT Hybrid Inverter



Sineng Electric Co., Ltd.

Version: A02

Copyright Statement

© 2026 Sineng Electric Co., Ltd. All rights reserved.

Sineng owns the patents, copyrights and other intellectual property rights for this product and its software. Without the written authorization of Sineng, no unit or individual may excerpt or copy the content of this manual. This product and its related parts may not be copied, manufactured, processed, or used directly or indirectly. No part or all of this manual may be used for commercial purposes in any form.

Trademarks and Permissions

 **SINENG** is a registered trademark owned by Sineng. It may not be used for other commercial purposes without the written authorization of the Sineng.

Disclaimer

Due to product updates, improvements or other reasons, the information and product in this manual will be updated from time to time. Sineng reserves the rights to modify the product and specifications in this manual without prior notice. The information in this manual is for reference only. The actual product shall prevail.

Sineng does not assume any direct, indirect, special, incidental or consequential losses and liabilities arising from improper use of this manual or this product, or related thereto.

Contact Method

Website: <https://www.si-neng.com/>

Preface

Thank you for choosing the product from Sineng Electric Co., Ltd. (hereinafter referred to as Sineng). This manual describes instructions on proper use of the product. Please read this manual carefully before using the product. Please keep this manual properly for future reference.

Overview





This manual mainly introduces the safety precautions, product introduction, installation, electrical connections, power-on commissioning, maintenance and technical indicators of the following energy storage converter models. This manual is designed to help you understand and use the product correctly. It can also be used as training and operational materials for operators, on-site maintenance personnel and other personnel.

Intended Audience

- Technical support engineers
- Commissioning engineers
- Maintenance engineers
- Hardware installation engineers

Symbol Conventions

The following symbols are used in the description of safety or critical information in this manual. Please highly dangerous to abide by the information marked with the following symbols.

Symbol	Description
 Danger	Indicates a hazard with a high level of risk which, if not avoided, will result in death or serious injury.
 Warning	Indicates a hazard with a medium level of risk which, if not avoided, could result in death or serious injury.
 Caution	Indicates that an unpredictable situation may occur, which, if not avoided, may result in equipment damage, performance deterioration, data loss, etc.
 Note	Indicates key information elaboration and operational tips.

Issue A01 (2026-02-15)

First release.

Issue A02 (2026-03-17)

Update the wiring diagram.

Contents

Preface.....	1
Contents.....	1
Chapter 1 Safety Precautions	1
1.1 Declaration	1
1.2 Personal Safety.....	2
1.2.1 General Requirements	2
1.2.2 Personnel Requirements.....	3
1.3 Electrical Safety.....	4
1.3.1 General Requirements	4
1.3.2 Ground Requirements.....	5
1.3.3 Wiring Requirements.....	6
1.4 Environment Requirements.....	6
1.4.1 General Requirements	7
1.4.2 Machinery Safety	8
1.4.3 General Requirements	9
1.4.4 Carrying Heavy Objects.....	9
1.4.5 Ladder Use Safety.....	10
Chapter 2 Transportation and Storage.....	12
Chapter 3 Product Overview.....	13
3.1 Product Model Description	13
3.2 Networking Application	13
3.3 Operating mode	16
3.3.1 System Operating mode	16
3.3.2 Inverter Run Mode.....	19
3.4 Function characteristics.....	21
3.5 Product Appearance.....	23
Chapter 4 Inspection Before Installation	28
4.1 Outer Packaging Inspection.....	28

4.2	Delivery Inspection	28
Chapter 5 Product Installation		29
5.1	Requirements for installation tool	29
5.2	Installation Environment Requirements.....	29
5.3	Installation Space Requirements.....	31
5.3.1	Installation of Single Inverter.....	31
5.3.2	Installation of multiple inverters	32
5.4	Installation Angle Requirements	33
5.5	Installation Load-bearing Requirements	34
5.6	Unpacking and Transportation.....	34
5.7	Installation of inverter.....	35
Chapter 6 Installing the Cables.....		38
6.1	Connecting the Ground Cable	39
6.2	Connect AC cable(on-grid) and AC cable(off-grid).....	41
6.3	Connecting the DC Power Cable.....	44
6.4	Connecting Battery Input Cable	46
6.5	Install Communication module.....	48
6.6	Install the Communication cable	49
6.6.1	Install Dry contact cable.....	50
6.6.2	Connect BMS/DRM communication cable.....	51
6.6.3	(Optional) Install Parallel signal cables.....	53
6.7	Smart Meter and CT Connection	55
Chapter 7 Check after Installation.....		58
Chapter 8 Power-On/Off		59
8.1	Power-On.....	59
8.2	Power-Off.....	60
Chapter 9 Power Insight App		61
9.1	Downloading the App	61
9.2	Registration.....	61
9.3	Login	64

9.4 Logout.....	65
9.5 Running mode.....	66
9.5.1 Self-use mode.....	66
9.5.2 Fixed-time-use Mode.....	68
9.5.3 Backup mode.....	70
9.5.4 Off-grid mode (Active setting).....	72
9.6 Function and parameter settings	72
9.6.1 Remote control.....	72
9.6.2 Battery Settings.....	74
9.6.3 Smart meter.....	77
9.6.4 On-grid minimum SOC.....	87
9.6.5 Off-grid minimum SOC.....	88
9.6.6 Low Battery SOC Protection	89
9.6.7 Forced charging.....	90
9.6.8 Automatic forced SOC calibration.....	90
9.6.9 Three-phase Imbalance	90
9.6.10 Export limit	95
9.6.11 DRM function	97
9.6.12 IPS Self Inspect (For Italy CEI0-21 Grid Only)	98
Chapter 10 List of Alarms	101
Chapter 11 Product Maintenance.....	109
11.1 Daily Inspection of Inverter.....	109
11.2 Periodic Inspection of Inverter	110
Appendix A System Specifications	111
Appendix B Electrical system wiring diagram	115
Appendix C Stopping the Inverter	117
Appendix D Removing the Inverter.....	118
Appendix E Disposal of the Inverter	119
Appendix F After-sales Service Information.....	120

Chapter 1 Safety Precautions

1.1 Declaration

Before transporting, storing, installing, operating, using or/and maintaining the equipment, please read this manual, operate in strict accordance with the instructions, and follow all safety precautions marked on the equipment and in the manual. In this manual, "equipment" refers to the products, software, components, spare parts and/or services related to this manual. The "company" refers to the manufacturer (producer), seller and/or service provider of the equipment. "You" refers to the person who transports, stores, installs, operates, uses and/or maintains the equipment.

The "Danger", "Warning", "Caution", and "Tips" in this manual do not cover all safety precautions that should be observed. You must also comply with relevant international, national or regional standards and industry practices. Sineng does not assume any liability caused by violation of safe operation requirements or violation of safety standards for the design, production and use of equipment.

This equipment should be used in an environment in line with the design specifications. Otherwise, equipment failure, equipment malfunction or component damage that may be caused will not be covered by the equipment warranty. **Sineng will not be liable for compensation for related personal injuries and property losses, etc.**

All operations such as transportation, storage, installation, operation, use and maintenance should comply with applicable laws, regulations, standards and specifications.

Reverse engineering, decompilation, disassembly, adaptation, implantation and other derivative operations on the equipment software are prohibited. It is not allowed to study the internal implementation logic of the equipment, obtain the source code of the equipment software, or infringe on intellectual property rights in any way, nor disclose the results of any equipment software performance test.

Sineng will not be liable for any of the following Circumstances or their resulting consequences:

- Equipment damage is caused by earthquakes, floods, volcanic eruptions, mudslides, lightning strikes, fires, wars, armed conflicts, typhoons, hurricanes, tornadoes, extreme weather, and force majeure;
- The equipment is not operated under the service conditions specified in this manual;
- The installation and application environment does not comply with relevant international, national or regional standards;

- The equipment is installed and used by unqualified personnel;
- Failure to operate the equipment according to the operating instructions and safety warnings in the product and manual;
- The equipment is disassembled, modified, or its software code is altered without authorization.
- Equipment damage is caused by transportation by the customer or third-party shipping company;
- Equipment damage is caused by storage conditions that do not meet the requirements described in the manual;
- The materials and tools prepared by the customer do not meet the requirements of local laws, regulations and relevant standards;
- Equipment damage is caused by customer or third party's negligence, intentionality, gross negligence, improper operation, or non-Sineng reasons.

1.2 Personal Safety



Danger

- It is prohibited to perform live operations during installation. It is prohibited to install or remove cables while the power is on. Arcing or sparks may occur at the moment when a cable core contacts a conductor, which may cause fire or personal injuries.
 - When the equipment is energized, non-standard or incorrect operations may cause fire, electric shock or explosion, resulting in casualties or property loss.
 - It is prohibited to wear watches, bracelets, rings, necklaces and other conductive accessories during the operation to avoid being burned by electric shock.
 - Special insulating tools must be used during the operation to avoid electric shock injuries or short-circuit faults. The insulation withstand voltage must meet local laws, regulations, standards and specifications.
-



Warning

- Special protective equipment must be used during the operation, such as protective clothing, Insulating shoes, goggles, hard hats, and Insulating gloves
-

1.2.1 General Requirements

- Do not deactivate equipment protection devices or ignore warnings, cautions and

preventive measures in the manual and equipment.

- During the operating of the equipment, if a fault that may cause personal injuries or equipment damage is discovered, immediately terminate the operation and report to the responsible personnel. Then, take effective protective measures.
- Do not power on the equipment before it has been installed or confirmed by professionals.
- It is prohibited to contact the power supply equipment directly, using other conductors, or indirectly through wet objects. Before contacting any conductive surface or terminal, measure the voltage of the contact point to confirm that there is no risk of electric shock.
- When the equipment is operating, the enclosure temperature is high and there is a risk of burns. Please do not touch the enclosure.
- It is prohibited to let your fingers, parts, screws, tools or boards come into contact with the running fan to avoid injuries to your hands or damage to the equipment.
- If fire occurs, evacuate the building or equipment area immediately and press the fire alarm or call the fire emergency hotline. Under no circumstances should you re-enter the burning building or equipment area.

1.2.2 Personnel Requirements

- Personnel operating the equipment include professionals and trained personnel.
 - Professionals: People who are familiar with the principles and structure of equipment, have experience in training or operating the equipment, and understand the potential sources and magnitudes of hazards during equipment installation, operation, and maintenance.
 - Trained personnel: People who have undergone appropriate technical and safety training, can be aware of the hazards that may arise when performing an operation, and can take steps to minimize the risk to themselves or other persons.
- Personnel who install and maintain the equipment must undergo strict training, master correct operation methods, and understand various safety precautions and relevant standards of the country/region where the equipment is located.
- Only qualified professionals or trained personnel are allowed to install, operate and maintain the equipment.
- Only qualified professionals are allowed to remove safety facilities and service equipment.
- Personnel operating in special scenarios such as electrical operations, climbing operations, and special equipment operations must have the special operation qualifications required by the local country/region.

- Replacement of equipment or parts (including software) must be implemented by authorized professionals.
- Except for those who operate the equipment, other personnel are prohibited to approach the equipment.

1.3 Electrical Safety



Danger

- Before making electrical connections, ensure that the equipment is not damaged. Otherwise, it may cause electric shock or fire.
 - Improper and incorrect operations may cause accidents such as fire or electric shock.
 - During the operation, prevent foreign objects from entering the equipment. Otherwise, it may cause short circuit or damage to the equipment, derating or power outage of the load, as well as personal injuries.
 - When installing equipment that needs to be grounded, the protective ground cable must be installed first. When dismantling the equipment, the protective ground cable must be removed last.
-

1.3.1 General Requirements

- Installation, operation and maintenance must be carried out in accordance with the procedures in the manual. Do not modify, install or change equipment without authorization, and do not change the installation sequence without authorization.
- On-grid operating requires the permissions from the power department of the country or region where the equipment is located.
- Comply with power station safety regulations, such as operation ticket and job ticket systems.
- Set up temporary fences or warning ropes in the working area and hang "No Entry" signs to prevent unrelated persons from entering the working area.
- Before installing or removing the power cables, disconnect the equipment and its upper-level and lower-level switches.
- Before operating the equipment, carefully check that the tools are qualified and registered. After the operation is completed, take the tools back according to the claimed quantity to prevent them from being left inside the equipment.
- Before installing power cables, confirm that the cable labels are correct and the cable

terminals are insulated.

- When installing the equipment, use a torque tool with an appropriate range to tighten the screws. When using a wrench to tighten, ensure that the wrench is not skewed and the error of torque does not exceed 10% of the specified value.
- Use a torque tool to secure the bolts and double check using the red and blue markings. After confirming that a bolt is tightened, paint a blue mark on the bolt. After the inspector confirms that the bolt is tightened, paint a red mark (the line mark must span the edge of the bolt).
- If the equipment has multiple inputs, all inputs of the equipment should be disconnected, and the equipment can only be operated after it is completely powered off.
- When maintaining the lower-level power consumption or power distribution equipment of the power supply equipment, it is necessary to disconnect the corresponding output switch of the power supply equipment.
- During equipment maintenance, hang a "No closing" sign on the upper-level and lower-level switches or circuit breakers, and post warning signs to prevent accidental connections. The equipment can only be powered on after the fault is rectified.
- Regularly check the equipment connection terminal screws to make sure they are tightened properly.
- If a cable is damaged, it must be replaced by a professional to avoid risks.
- It is prohibited to alter, damage or cover the signs and nameplates on the equipment, and promptly replace unclear signs that have been used for a long time.
- It is prohibited to clean the internal and external electrical parts of the equipment with solvents such as water, alcohol or oil.

1.3.2 Ground Requirements

- The equipment ground impedance should meet the requirements of local electrical standards.
- The equipment must be connected to the protection ground. Before operating the equipment, check the electrical connection of the equipment to ensure that the equipment is reliably grounded.
- It is prohibited to operate the equipment when the grounding conductor is not installed.
- It is prohibited to destroy the grounding conductor.

1.3.3 Wiring Requirements

- The selection, installation, and routing of cables must comply with local laws, regulations, and specifications.
- Looping and twisting of cables are prohibited. If the length of the power cable is not long enough, replace the power cable. It is prohibited to make joints or solder joints in the power cable.
- All cables must be securely connected, well insulated, and of appropriate size.
- Cable troughs and cable holes should have no sharp edges. Cable tubes or cable holes must be protected to prevent cables from being damaged by sharp edges, burrs, etc.
- Cables of the same type should be tied together, with a straight and neat appearance and no skin damage. Cables of different types should be laid out separately, and cables must not entangle or cross each other.
- Buried cables need to be reliably secured using cable supports and cable clamps. The cables in the backfilled soil area must be closely attached to the ground to prevent the cables from being deformed or damaged due to force exerted when the soil is backfilled.
- When external conditions (such as laying methods or ambient temperature) change, verify cable selection by referring to IEC-60364-5-52 or local regulations and specifications, such as whether the current carrying capacity meets the requirements.
- The insulation layer of cables may be aged or damaged if the cables are used in high-temperature environments. The distance between the cable and the heating device or the periphery of the heat source area must be at least 30 mm.
- The torsion angle between the plane of the OT terminal of the power cable and the plane of the input copper bar should not exceed 15 degrees.
- After the power cables are installed, tie them to the supports.
- Cable routing should avoid the line cutting position of the platform.
- The torsion angle between the central axis of the power cable and the input copper bar in the vertical direction should be less than 5 degrees.

1.4 Environment Requirements



Danger

- It is prohibited to place the equipment in an environment with flammable or explosive gases or smoke, or perform any operation on the equipment in such environment.
 - It is prohibited to store flammable and explosive items in the equipment area.
-

- It is prohibited to place the equipment close to heat or fire sources, such as fireworks, candles, heaters, or other heating devices. The heating may cause damage to the equipment or cause a fire.
 - The equipment should be installed in an area away from liquids. It is prohibited to install the equipment under water pipes, air outlets and other places where condensation is likely to occur. It is prohibited to install the equipment under air conditioners, vents and other places that are prone to water leakage to prevent liquid from entering the equipment and causing equipment failure or short circuit.
-

**Warning**

- When the equipment is operating, do not block the air outlets and cooling system, or cover it with other objects to prevent equipment damage or fire due to high temperature.
 - The equipment should be installed in an area away from liquids. It is prohibited to install the equipment under water pipes, air outlets and other places where condensation is likely to occur. It is prohibited to install the equipment under air conditioners, vents and other places that are prone to water leakage to prevent liquid from entering the equipment and causing equipment failure or short circuit.
-

1.4.1 General Requirements

- The equipment should be stored in a suitable temperature and humidity environment, where is clean, dry, and well-ventilated. It should be protected from dust and condensation.
- It is prohibited to install and operate the equipment beyond the range specified by the technical specifications. Otherwise, the performance and safety of the equipment will be affected.
- It is prohibited to install, use and operate outdoor equipment and cables (including but not limited to handling the equipment, operating the equipment and cables, plugging and pulling signal interfaces connected outdoors, performing high-altitude work and outdoor installation, and opening doors) in severe weather such as lightning, rain, snow, and strong winds above level 6.
- It is prohibited to install the equipment in an environment with dust, smoke, volatile gases, corrosive gases, infrared and other radioactive rays, organic solvents or excessive salt content.
- It is prohibited to install the equipment in an environment with metal conductive dust or magnetic conductive dust.

- It is prohibited to install the equipment in areas prone to the growth of fungi, mold and other microorganisms.
- It is prohibited to install the equipment in areas with strong vibration, strong noise sources and strong electromagnetic field interference.
- Site selection should comply with local laws, regulations and relevant standards.
- The installation environment should have a solid ground, without rubber soil, soft soil, or unfavorable geology such as easy sinking. Low-lying areas that are prone to water accumulation or snow accumulation are not allowed. The site level should be higher than the historical highest water level in the area.
- It is prohibited to install the equipment in a place where water can flood it.
- If the equipment is installed in a place with lush vegetation, in addition to routine weeding, the ground under the equipment needs to be hardened, such as laying cement, stones, etc.
- Equipment installed in soil salinization areas will be corroded. Please do not install it outdoors in soil salinization areas. Soil salinization areas refer to areas within 500 m from the coast or affected by sea breezes. The areas affected by sea breezes vary depending on meteorological conditions (such as typhoons and seasonal winds) or topography (such as dams and hills).
- During installation, operation, and maintenance, the accumulated water, ice, snow or other debris on the top must be cleared first.
- When installing the equipment, ensure that the installation surface is solid and meets the load-bearing requirements.
- After installing the equipment, empty packaging materials such as cartons, foam, plastic, and binding straps should be removed from the equipment area.
- It is strictly prohibited to install and store the product in a sandy and dusty environment.

1.4.2 Machinery Safety



Warning

- Tools must be fully prepared and have passed inspection by professional institutions. It is prohibited to use tools that are damaged or have failed the inspections or have exceeded the validity period. Ensure that the tools are firm and non-overloaded.
 - It is prohibited to drill holes in the equipment. Drilling will destroy the sealing, electromagnetic shielding performance, internal components and cables of the equipment. Metal shavings generated by drilling will enter the equipment, which will
-

cause a short circuit on the circuit board.

1.4.3 General Requirements

- Paint scratches that occur during equipment transportation and installation must be repaired in a timely manner. It is prohibited to expose the scratched part for a long time.
- Arc welding, cutting and other operations on the equipment are prohibited without evaluation by Sineng.
- It is prohibited to install other devices on the top of the equipment without evaluation by Sineng.
- When working in the space above the top of the equipment, add protection on the top of the equipment to avoid damage to the equipment.
- Please use correct tools and master correct use methods.

1.4.4 Carrying Heavy Objects

- When carrying heavy objects, prepare to bear the weight to avoid being crushed or sprained by the heavy objects.

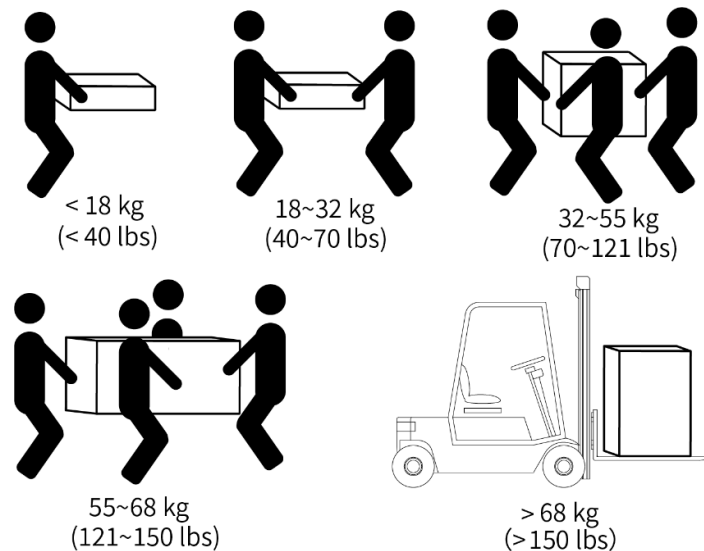

- When multiple people are carrying heavy objects together, height and other conditions must be considered. Reasonably arrange the people and work to ensure balanced weight distribution.
- When two or more people are carrying heavy objects together, one person should direct them to lift or put down the equipment at the same time to ensure uniform steps.
- When handling equipment by hand, wear protective gloves, protective shoes and other safety equipment to avoid injuries.

- When handling equipment by hand, approach the object, squat down, and use the power of straightening your legs instead of your back to lift the object slowly and steadily. It is prohibited to suddenly lift the object or twist your trunk.
- Do not quickly lift the heavy object above waist. Place the heavy object on a workbench at half waist height or a suitable place, adjust the position of your palms, and then lift it up.
- Handle the heavy object with balanced and steady force. Move or place it stably and slowly to avoid any impact or drop from scratching the surface of the equipment or damaging the components and cables of the equipment.
- When handling the heavy object, exercise caution at workbenches, slopes, stairs and other places where there are slippery. When carrying the heavy object through the doorsill, make sure the door is wide enough to allow the equipment to pass through, so as to prevent injuries or scratches on your fingers.
- When transferring the heavy object, move your feet rather than twisting your waist. When you need to lift and transfer the heavy object at the same time, point your feet in the direction to move, and then carry the heavy object.
- When using a forklift to handle the equipment, ensure that the forklift is in the middle position to prevent it from tipping over. Before moving the equipment, fasten the equipment to the forklift using ropes. When moving the equipment, special personnel are required to supervise the process.
- Transport the equipment by sea, highway with good road conditions, or air. Railway transportation is not supported. Bumps and tilts should be minimized during transportation.

1.4.5 Ladder Use Safety

- When performing live operations at heights, use wooden ladders or insulated ladders.
- It is preferred to use platform ladders with guardrails. Trestle ladders are not recommended.
- Before using the ladder, ensure that it is in good conditions and meets the load-bearing requirements. It is prohibited to use it in the overloaded state.
- The ladder must be placed in a stable place and someone must hold the ladder when you are working on the ladder.

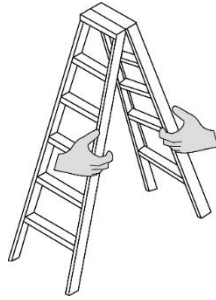

- When climbing a ladder, keep your body steady and ensure that your body's center of gravity does not deviate from the edge of the ladder frame to ensure your safety.
- The drawstring must be secure when using a ladder.
- If a trestle ladder is used, the inclination of the ladder should be 75° , which can be measured using a steel square, as shown in the following figure.

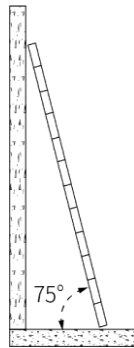

- If a trestle ladder is used, place the wide ladder legs downward or use protective measures at the bottom of the ladder to prevent slipping.
- If a trestle ladder is used, the maximum height of the feet should not exceed the fourth step from the top to the bottom of the ladder.
- If a trestle ladder is used to climb up to the platform, the vertical height of the ladder beyond the platform must be at least 1 meter.

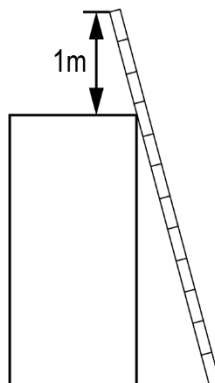

Chapter 2 Transportation and Storage

Transportation Requirements

- Choose the appropriate transportation tool based on the dimensions and weight of the equipment.
- Keep the equipment level during transportation.
- It is strictly forbidden for machines without packaging transportation.
- During transportation, collisions and severe vibrations are prohibited.
- The equipment must be transported in compliance with relevant local regulations and standards.

Storage Requirements

If the inverter is not put into use immediately, ensure that the following storage conditions are met:

- Do not remove the outer packaging and inspect it regularly (it is recommended to inspect it every three months). If you find any insect bites or damage to the packaging, replace the packaging in a timely manner. If the inverter has been unpacked but will not be put into use immediately, put it back into its original packaging, keep the desiccant, and seal it with tape.
- Storage ambient temperature: -40°C to $+70^{\circ}\text{C}$; storage ambient relative humidity: 0 to 95% (non-condensing).
- Do not store the inverter in places with chemical corrosive substances and mice.
- The inverter should be stored in a dry, clean and ventilated indoor environment. Avoid direct sunlight and exposure to the sun, rain, humidity and acid mist.
- The storage location of the inverter should be strong enough to support the weight of the inverter for a long time and avoid vibration or impact to the inverter.
- When stacking inverters, please place them carefully to avoid personal injury or equipment damage caused by equipment tilting.
- When storing, the storage inverter is placed strictly in the direction of the "upward" marked in the outer box. It is strictly prohibited to tilt or turn the packaging boxes upside down. The stacking layer cannot exceed the "maximum stack layer limit" marked by the box.
- When the storage time is two years or longer, the inverter must be inspected and tested by professionals before it can be put into use.

Chapter 3 Product Overview

The inverter may control and optimize energy flow in the PV system through an integrated energy management system. The electricity generated in the PV system can be used by the load, stored in the battery, and transferred to the power grid.

The following types of inverters are applicable:

- SN20HT
- SN25HT
- SN29.9HT
- SN30HT
- SN33HT

3.1 Product Model Description

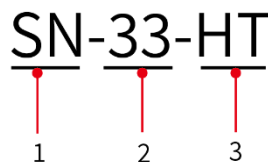

Figure 3-1 Product Model

Table 3-1 Product Model Description

Sign	Meaning	Value
1	Brand code	Sineng Electric
2	Rated output power	Rated output power at 33 kW
3	System classification	Hybrid system (Three phase)

3.2 Networking Application



Warning

- PV systems are not suitable for connection to devices that rely on a stable power supply, such as life-sustaining medical equipment. Please ensure that there is no risk of personal injury Even when the system being shut down.
- Please try to avoid using loads with high starting current in the PV systems, such as high-power water pumps, as this may result in off-grid output failure due to excessive instantaneous power.
- A BACK-UP function is recommended if no battery is used in the PV system. Otherwise, the

resulting system operation risks are not covered by the warranty.

- The battery current may be limited by some factors, such as temperature, humidity, And weather conditions, etc., thus affecting the load capacity.
- If rapid shutdown module is in the PV system, please ensure that the rapid shutdown module used in the PV string has the same model as the inverter's built-in transmitter. If not, the run-off function may fail.
- When the inverter trips on the overload protection at a time, the inverter can automatically restart. If it occurs repeatedly, it may take more time to restart. The inverter may be shortly restarted by the App whenever required.
- In case of excessive load capacity beyond the rated power of the inverter during grid outage, the inverter's off-grid function will automatically turn off. To restart, turn off the high-power load to ensure that the load power is less than the rated power of the inverter.
- The inverter at the off-grid mode can be used for household loads, such as:
 - Inductive load、Capacitive load: total power $\leq 0.5x$ rated output power of the inverter.
 - Motor loads such as air conditioners and water pumps have a starting current that is 5 to 7 times their rated current. The rated power of the lode should be less than 1/5 to 1/7 of the inverter's off-grid peak power. (Rated load power $< \frac{\text{Off-grid peak power}}{5\sim7}$)

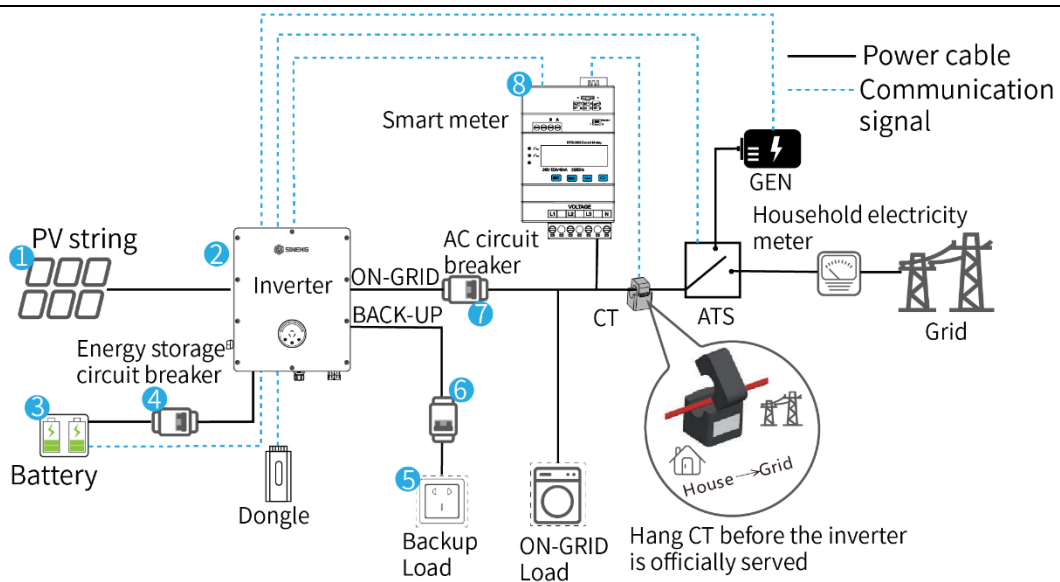

Figure 3-2 System scheme

SN	Parts	Description
1	PV string	PV string consists of PV modules
2	Inverter	Applicable inverters: SN20HT/SN25HT/SN29.9HT/SN30HT/SN33HT series.

3	Battery	Select the appropriate models based on the matching table of the inverter and battery. and obtain the approved list of batteries from the website or via the APP.
4	Energy storage circuit breaker	Recommended capacity: rated current $\geq 60A$, rated voltage $> 1000V$.
5	Backup load	Support connection of standby loads, such as other important loads.
6	Backup circuit breaker	To be specified in conjunction with the actual load.
7	AC circuit breaker	Recommended specification: SN20HT: Rated current 63A SN25HT: Rated current 63A SN29.9HT: Rated current 80A SN30HT: Rated current 80A SN33HT: Rated current 80A
8	Smart meter	To be purchased from the inverter manufacturer, recommended model: AC smart meter-DTSU666.

The power grids supported by SN20HT / SN25HT / SN29.9HT / SN30HT / SN33HT are TN-S, TN-C, TN-C-S, TT and IT.

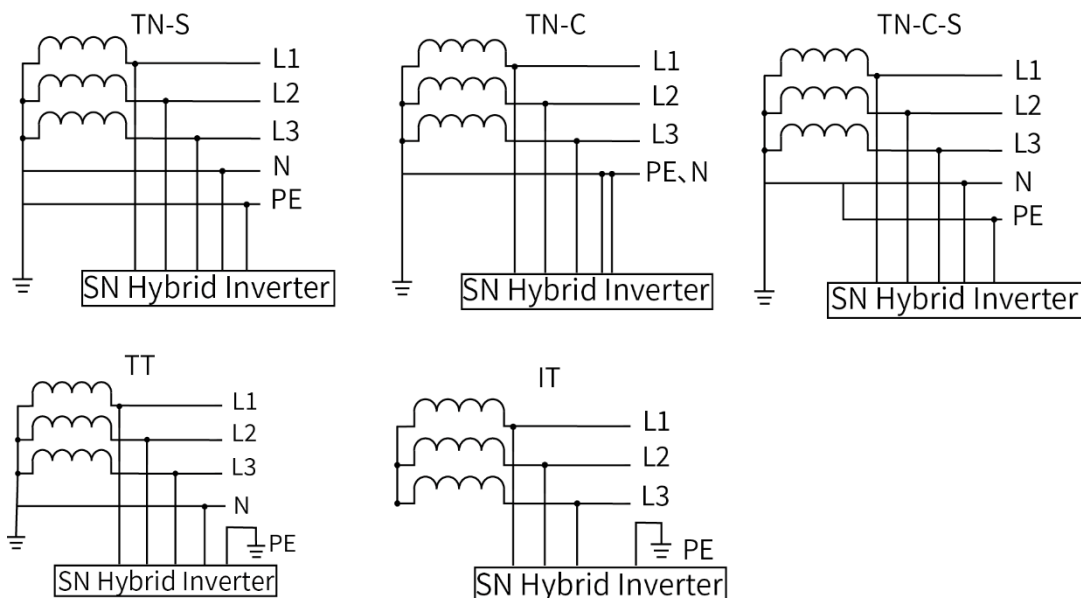

Figure 3-3 Power Grid supported by SN Series Hybrid Inverter

3.3 Operating mode

3.3.1 System Operating mode

Self-use mode

Overview:

The self-use function can adjust the power of PV, battery, and power grid based on the meter power. Given the enabled power meter and normal communication, energy flow will be adjusted based on the power of the meter. The inverter, when the grid is cut off, will automatically switch to the off-grid mode.

The inverter defaults to self-use mode.

The electricity generated by PVs, if sufficient, is supplied to the load in priority while the surplus is used to charge the battery. And any remaining electricity, if any, will be sent to the grid.

When the electricity generated by PVs is insufficient to supply the load, but the PV and battery can support the loads, the PV and battery will supply the loads.

When the PV and battery are not sufficient to supply the loads, PV and battery together with the grid will supply the loads.

Forced charging option in winter

In winter, to prevent excessive energy use and prevent battery abnormalities, as well as retain more energy for emergencies, a forced-charge option is designed. There are two time periods. If the winter option is selected, the inverter will forced-charge the battery according to the set charging power within the set time until the set SOC value is reached.

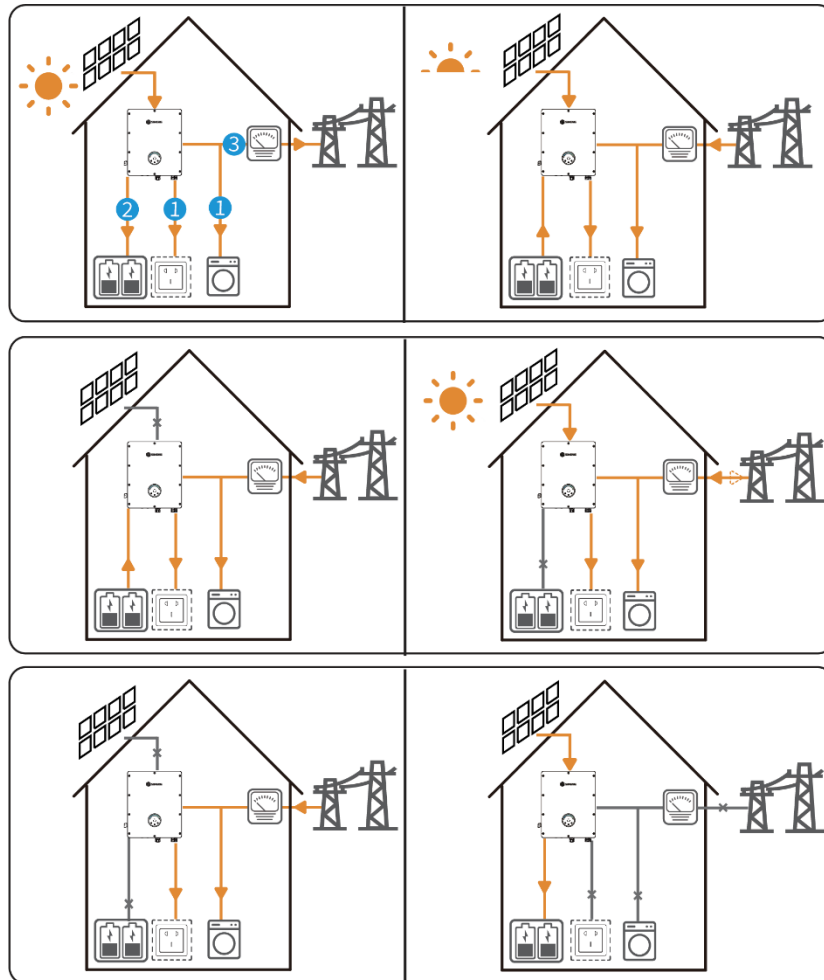

Figure 3-4 Self-use mode

TOU mode

We can set certain days of the week or certain times of the day to charge or discharge the battery. When the current SOC (State of Charge) is greater than the minimum SOC for grid connection, the battery will be charged and discharged as usual.

Discharging will stop when the current SOC is less than or equal to the minimum SOC for grid connection. Furthermore, forced-charging is also controlled by the battery command (forced-charging is prioritized when required by the battery).

When the battery is under abnormal condition, charging or discharging will be stopped. The inverter, when the grid is cut off, will automatically switch to the off-grid mode.

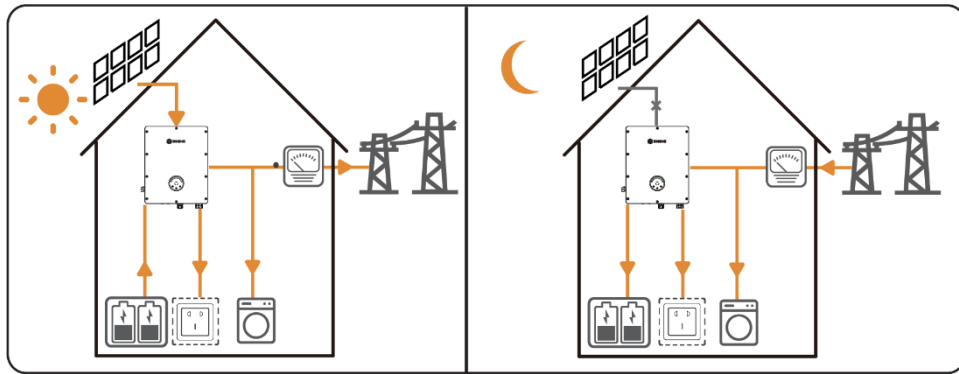

Figure 3-5 TOU mode

Backup mode

The battery can only be discharged when the main power is abnormal and can be used as an emergency power source.

The inverter, when the power grid is cut off, may automatically switch to the off-grid mode. Maintain the battery's current SOC above the minimum On-grid SOC.

When the current SOC is less than the minimum On-grid SOC, it will be charged to the hysteresis point of the minimum On-grid (minimum SOC+2%).

Given the current SOC at 95% - 100%, in order to reduce the waste of electricity caused by taking power from the power grid, priority will be given to ensuring the EPS power supply, and excess energy will be fed to charge to the battery.

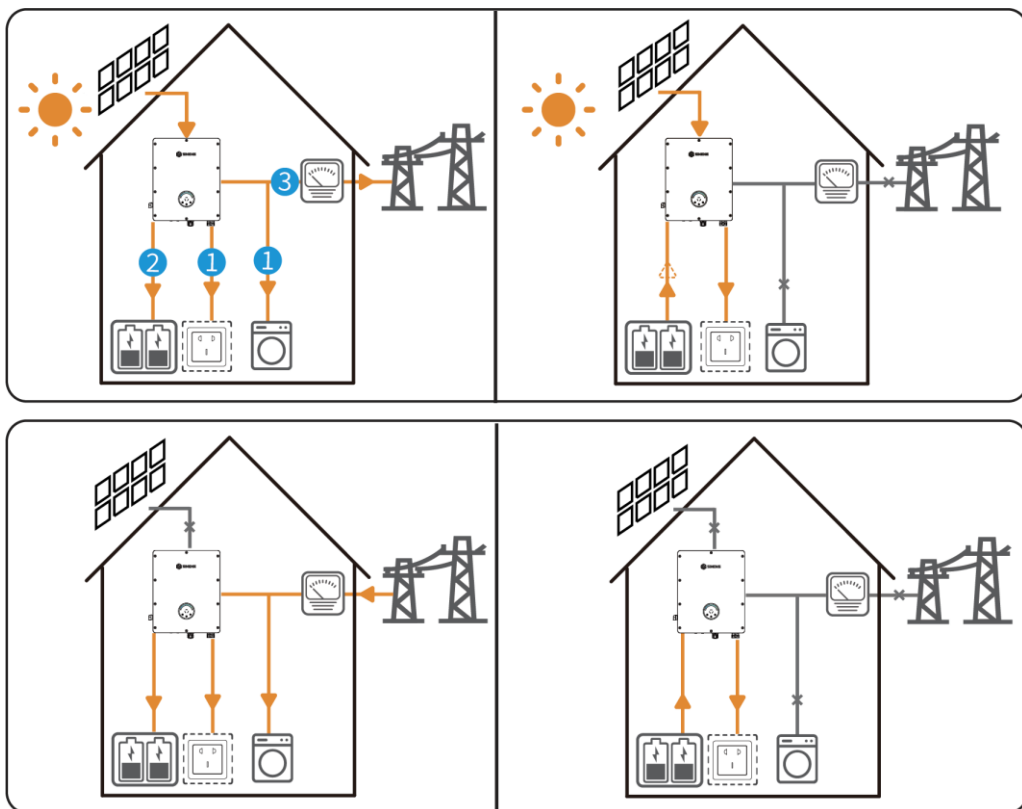

Figure 3-6 Backup mode

Forced off-grid mode

A pure off-grid system consisting of PV, batteries, and loads is suitable for areas without grids. In this mode, the inverter can be forced to disconnect from the grid and runs in the off-grid mode. Under such circumstances, the inverter can neither send power to the grid or take power from the grid.

This mode can only function in the on-grid mode. Battery charging and discharging are not controlled by this in off-grid mode (including no mains supply).

The Compatibility for Backup under Off-grid Scenario

The information below is about the compatibility for backup of SN20HT/ SN25HT/ SN29.9HT/ SN30HT/ SN33HT inverter under off-grid scenario. Please refer to this information before you use the back-up model of the four inverters under off-grid situation. When the PV voltage exceeding 900V, the back-up side will operate at the reduced rate.

Main electrical panel

The data of the compatibility for backup of SN20HT/ SN25HT/ SN29.9HT/ SN30HT/ SN33HT are based on the test with batteries (SOC、Temperature). For the actual application, please refer to the maximum output capacity of the battery.

3.3.2 Inverter Run Mode

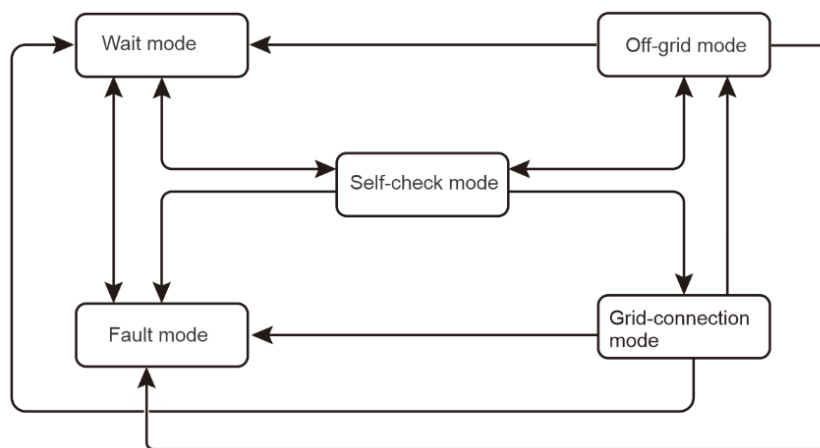

Figure 3-7 Inverter run mode

Table 3-2 Inverter run mode

SN	Parts	Description
1	Wait mode	Wait stage when the machine is powered on <ul style="list-style-type: none"> ● Enter the self-check mode when conditions are met. ● In case of fault, the inverter is switched to the fault mode.
2	Self-check	The inverter, before startup, shall continuously perform self-check,

	mode	<p>initialization, etc.</p> <ul style="list-style-type: none"> ● When conditions are met, enter the grid-connection mode so that the inverter starts On-grid operation. ● If no grid is detected, enter the off-grid mode so that the inverter starts off-grid operation. Given the inverter is lack of off-grid function, enter the wait mode. ● If self-check fails, enter the fault mode.
3	Grid-connection mode	<p>The inverter performs the grid-connection operation as usual.</p> <ul style="list-style-type: none"> ● If detection shows grid absence, enter the off-grid working mode. ● If fault is detected, enter the fault mode. ● If it is detected that the grid condition does not meet the grid-connection requirements, and no off-grid output function is activated, enter the wait mode.
4	Off-grid mode	<p>In case of power failure, the inverter is switched to the off-grid mode from the working mode so as to continuously supply power to the loads.</p> <ul style="list-style-type: none"> ● If fault is detected, enter the fault mode. ● If it is detected that the grid condition does not meet the grid-connection requirements, and no off-grid output function is activated, enter the wait mode. ● If it is detected that the grid conditions meet the grid-connection requirements, and off-grid output function is activated, enter the self-check mode.
5	Fault mode	<p>If fault is detected, the inverter enters the fault mode, and enters the wait mode after fault clearance.</p>



Note

- When the inverter is powered on for the first time, there must be a normal AC voltage on the grid side; otherwise, the inverter's relay will not be able to perform self-inspection, resulting in the inverter's inability to start up properly. If you want the inverter to operate, you can choose to enter off-grid mode, which allows the inverter to function independently of the grid. After the inverter has completed its initial power-up self-inspection, you can proceed with mode switching as indicated in the above diagram.

3.4 Function characteristics

Power derating

For safe operation, the inverter will automatically reduce the output power under the non-optimum condition. The following factors may cause power derating, please try to avoid them during use.

- Unfavorable environmental condition, such as direct exposure to sunshine, high temperature, etc.
- Inverter's output power percentage has been set.
- Load shedding due to over frequency.
- The input voltage is too high or too low.
- The input current is high.

AFCI (By default, this function is closed)

Causes of electric arc:

- Inadequate connector connection in the PV system or battery system.
- Cable connection is incorrect or damaged.
- Connector, cable are aging.

Electric arc detection method

- Inverter integrated AFCI function.
- When the inverter detects an electric arc, an indication of the time and phenomenon of the fault can be displayed through the App.
- If the inverter trips less than 5 times within 24h, the alarm can be automatically cleared. The inverter will be shut down for protection on the 5th arc fault trip. The inverter may not resume operation until the fault is cleared.

RSD (Optional)

The inverter is equipped with a built-in signal transmitter that can communicate with an external unit module-level disconnecter. In case of the emergency, the transmitter can be disabled by enabling the external emergency switch to shut down the module.

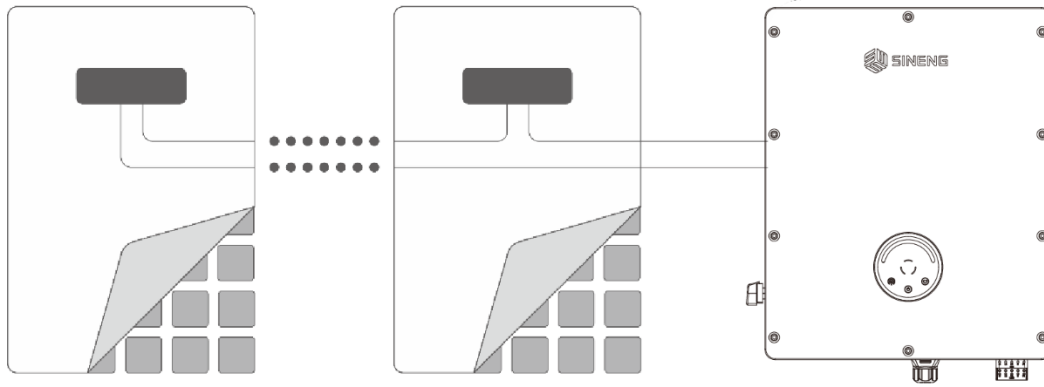

Figure 3-8 RSD function

Earth Fault Alarm

The inverter is equipped with the reserved port used for earth fault alarm.

In case of earth fault, the LED fault light of the inverter will be On.

3.5 Product Appearance

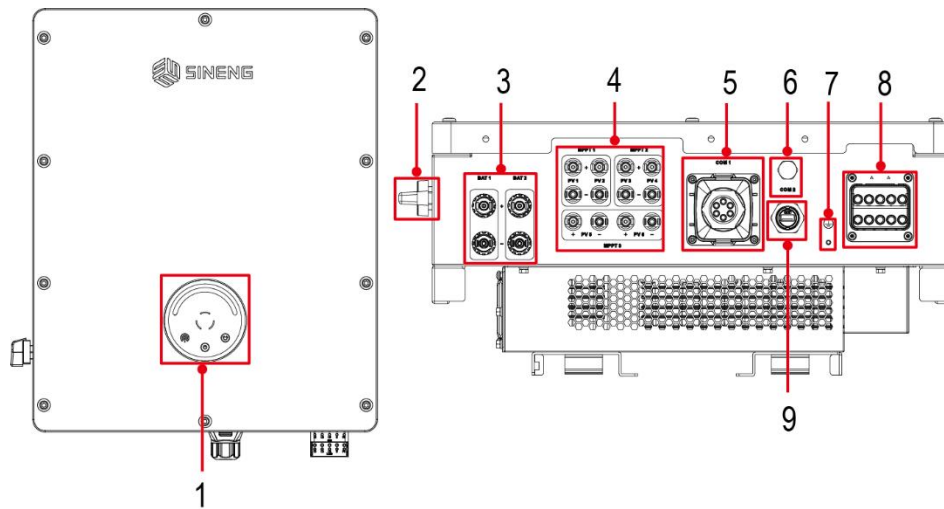









Figure 3-9 Appearance and dimensions

Table 3-3 Component description

SN	Name	Description
1	Indicator light	Indicate the inverter's operation state.
2	DC switch	Control DC input On /Off
3	Energy storage DC input port (BAT)	To connect battery DC input cable
4	PV input port	To connect PV module DC input cable
5	Communication port	To connect external communication and monitoring
6	Vent Valve	It balances the internal and external pressure and discharges the gas inside the equipment.
7	Protective ground terminal	Connect protective ground wire
8	On-grid/ Off-grid terminal	To connect AC grid cables/ To connect the AC critical load cable
9	Communication module interface	To connect external APP and cloud platform

Indicator

Table 3-4 Indicator description

Symbol	State	Meaning
	Red	Fault
	Yellow	Warning, but system is still operating
	Blue	Operating
	Blink	Wait
	Blink	Interacted with RS485 or USB
	OFF	Not interacted with RS485 and USB
	ON	Grid is active and bypass is connected
	Blink	Back-up is ready/Power available
	OFF	Back-up is off
	Blink	Battery is charging, and SOC > 75%
	ON	Battery is discharging, and SOC > 75%
	Blink	Battery is charging, and SOC > 50%
	ON	Battery is discharging, and SOC > 50%
	Blink	Battery is charging, and SOC > 25%
	ON	Battery is discharging, and SOC > 25%
	Blink	Battery is charging, and SOC > 10%
	ON	Battery is discharging, and SOC > 10%
	OFF	Battery SOC < 10%, or interaction

Communication port

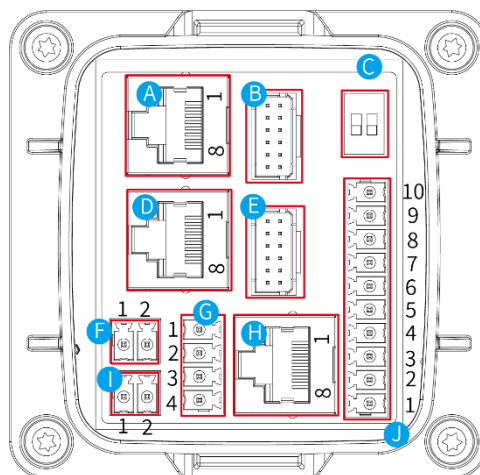
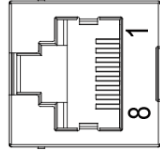
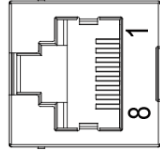
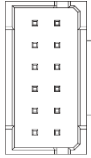
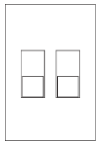

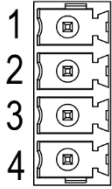
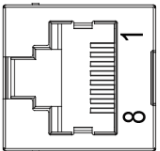
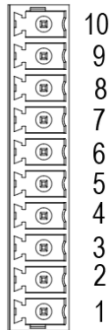

Figure 3-10 Communication port







Table 3-5 Port description





Port	Port appearance	Name	PIN	Description	
A		BMS 2	1	NC	
			2	NC	
			3	NC	
			4	CAN_H_BMS	
			5	CAN_L_BMS	
D			BMS 1	6	NC
				7	NC
				8	NC
				9	PE
				10	
B			Parallel interface 2	\	For use in inverter paralleling
E			Parallel interface 1		
C			DIP switch	\	The initial status of DIP switches 1 and 2 is OFF. For single-unit operation, ensure the DIP switches remain OFF.
F			DO	1	DO_NO_2
2				DO_COM_2	
I			DO	1	DO_NO_1
				2	DO_COM_1
G			DI	1	DI_OUT1
				2	GND
		3		DI_OUT2	
		4		GND	
H		DRM	1	GND	
			2	+5V	
			3	COM/DRM0_OUT	
			4	DRM1/5_OUT	
			5	DRM2/6_OUT	
			6	DRM3/7_OUT	

			7	DRM4/8_OUT
			8	DRM_COM
			9	PE
			10	
J		RS485	10	+5V
			9	GND
			8	485_A_MULT
			7	485_B_MULT
			6	GND
			5	+12V OUT
			4	Reserve
			3	Reserve
			2	485_B_METER
			1	485_A_METER

Product Sign Description

Table 3-6 Product Sign Description

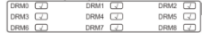
Sign	Description
	This sign indicates that it shall be noted.
	This sign indicates that there is high voltage inside the equipment. Touching the equipment may cause electric shock.
	This sign indicates that the temperature here is beyond the acceptable range of the human body. Please do not touch it to avoid personal burns.
	Maintenance, inspection and other operations can only be carried out after the energy storage converter is powered off for 10 minutes.
	Professionals should refer to the user manual when installing or maintaining the inverter.
	If the user intends to discard this product, it must be sent to an appropriate place for recovery and recycling, which cannot be disposed of as domestic waste.
	This product complies with CE certification.

	This product complies with TUV certification.
	This product complies with RCM certification.
	This product complies with DRM certification.
	This sign indicates the protective earth terminal, which needs to be reliably grounded to ensure the safety of operators.

Nameplate

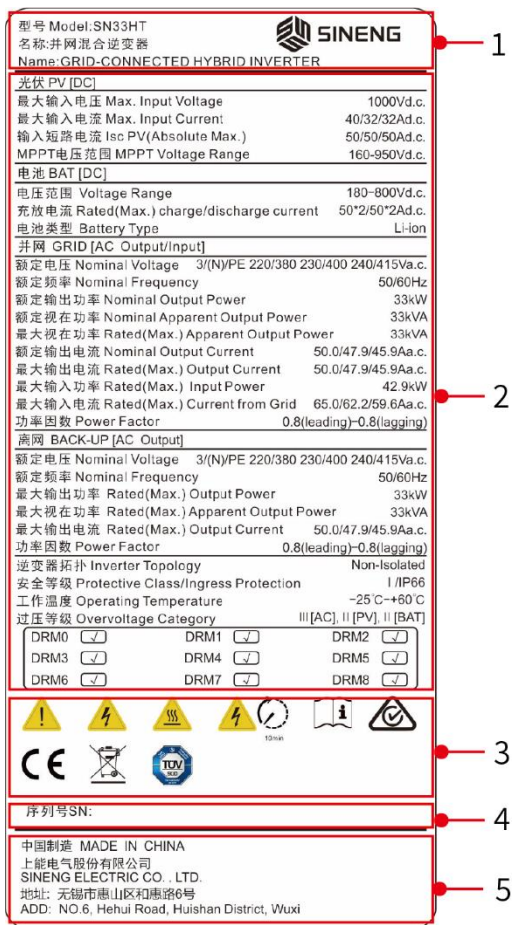

型号 Model: SN33HT
名称: 并网混合逆变器
Name: GRID-CONNECTED HYBRID INVERTER

光伏 PV [DC]
 最大输入电压 Max. Input Voltage 1000Vd.c.
 最大输入电流 Max. Input Current 40/32/32Ad.c.
 输入短路电流 Isc PV(Absolute Max.) 50/50/50Ad.c.
 MPPT电压范围 MPPT Voltage Range 160-950Vd.c.

电池 BAT [DC]
 电压范围 Voltage Range 180-800Vd.c.
 充放电电流 Rated(Max.) charge/discharge current 50*2/50*2Ad.c.
 电池类型 Battery Type Li-ion

并网 GRID [AC Output/Input]
 额定电压 Nominal Voltage 3/(N)/PE 220/380 230/400 240/415Va.c.
 额定频率 Nominal Frequency 50/60Hz
 额定输出功率 Nominal Output Power 33kW
 额定视在功率 Nominal Apparent Output Power 33kVA
 最大视在功率 Rated(Max.) Apparent Output Power 33kVA
 额定输出电流 Nominal Output Current 50.0/47.9/45.9Aa.c.
 最大输出电流 Rated(Max.) Output Current 50.0/47.9/45.9Aa.c.
 最大输入功率 Rated(Max.) Input Power 42.9kW
 最大输入电流 Rated(Max.) Current from Grid 65.0/62.2/59.6Aa.c.
 功率因数 Power Factor 0.8(leading)-0.8(lagging)

离网 BACK-UP [AC Output]
 额定电压 Nominal Voltage 3/(N)/PE 220/380 230/400 240/415Va.c.
 额定频率 Nominal Frequency 50/60Hz
 最大输出功率 Rated(Max.) Output Power 33kW
 最大视在功率 Rated(Max.) Apparent Output Power 33kVA
 最大输出电流 Rated(Max.) Output Current 50.0/47.9/45.9Aa.c.
 功率因数 Power Factor 0.8(leading)-0.8(lagging)

逆变器拓扑 Inverter Topology Non-Isolated
 安全等级 Protective Class/Ingress Protection I/IP66
 工作温度 Operating Temperature -25°C~+60°C
 过压等级 Overvoltage Category III [AC], II [PV], II [BAT]

DRM0 DRM1 DRM2
 DRM3 DRM4 DRM5
 DRM6 DRM7 DRM8

CE, TUV, RCM, and other safety symbols.

序列号 SN:

中国制造 MADE IN CHINA
 上能电气股份有限公司
 SINENG ELECTRIC CO., LTD.
 地址: 无锡市惠山区和惠路6号
 ADD: NO.6, Hehui Road, Huishan District, Wuxi

Figure 3-11 Nameplate

- | | | | | | |
|---|-----------------------------|---|------------------------|---|--|
| 1 | Trademark and product model | 2 | Product specifications | 3 | Product safety symbols and certification marks |
| 4 | Serial number | 5 | Manufacturer | | |

Chapter 4 Inspection Before Installation

4.1 Outer Packaging Inspection

Before unpacking the inverter, check the outer packaging for visible damage, such as holes, cracks, or other signs of possible internal damage, and check the inverter serial number. If there is any anomaly in the packaging or the inverter model number does not match, do not open it and contact your dealer as soon as possible.

4.2 Delivery Inspection

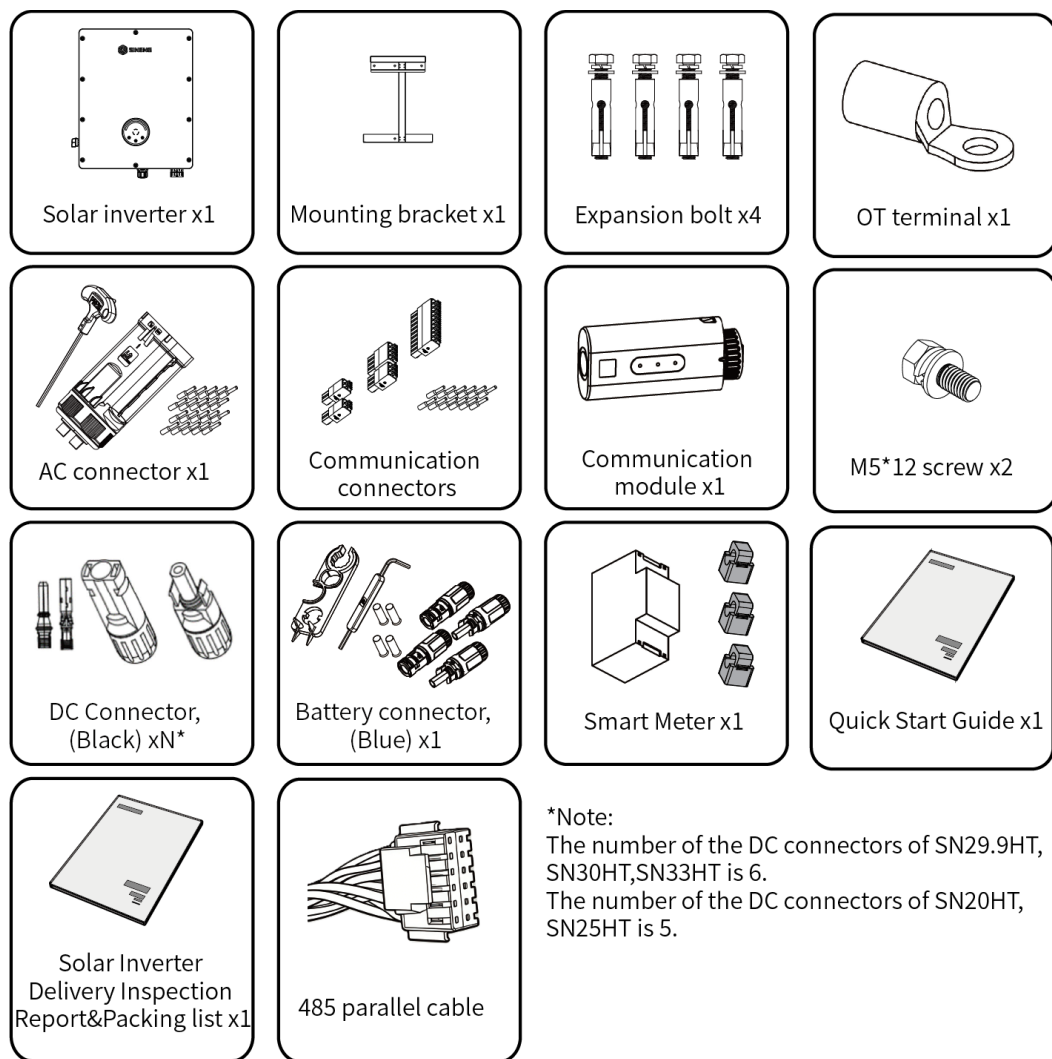

Figure 4-1 List of deliverables

Chapter 5 Product Installation

5.1 Requirements for installation tool

For installation the following installation tools are recommended. Other auxiliary tools can be used on site if necessary.



Figure 5-1 Tools recommended for installation

5.2 Installation Environment Requirements

- The equipment cannot be installed in flammable, explosive, corrosive or other alike environments.
- Please avoid the water pipes and cables in the wall to avoid danger when drilling holes for installation.
- The equipment protection level meets the requirements for indoor and outdoor installation, and the temperature and humidity of the installation environment must be within the

appropriate range.

- The inverter needs to be installed away from sunshine, rain, snow, and other alike environments. It is recommended to install it in a sheltered location. If necessary, a sunshade can be built.
- The installation space must meet the requirements for ventilation, heat dissipation and operation.
- The installed equipment should be out of reach for children, and should not be in places that are easy to touch. The surface of the equipment may be hot when it is in operation, take caution to avoid burns.
- The inverter installation altitude should be less than 4000m (the maximum working al
- Keep away from strong magnetic field to avoid electromagnetic interference. If there are radio stations or wireless communication equipment below 30MHz nearby, please install the equipment according to the following requirements:
 - Add a ferrite core with multi-turn windings at the DC input line or AC output line of the inverter, or add a low-pass EMI filter.
 - The distance between the inverter and the wireless electromagnetic interference equipment exceeds 60m.

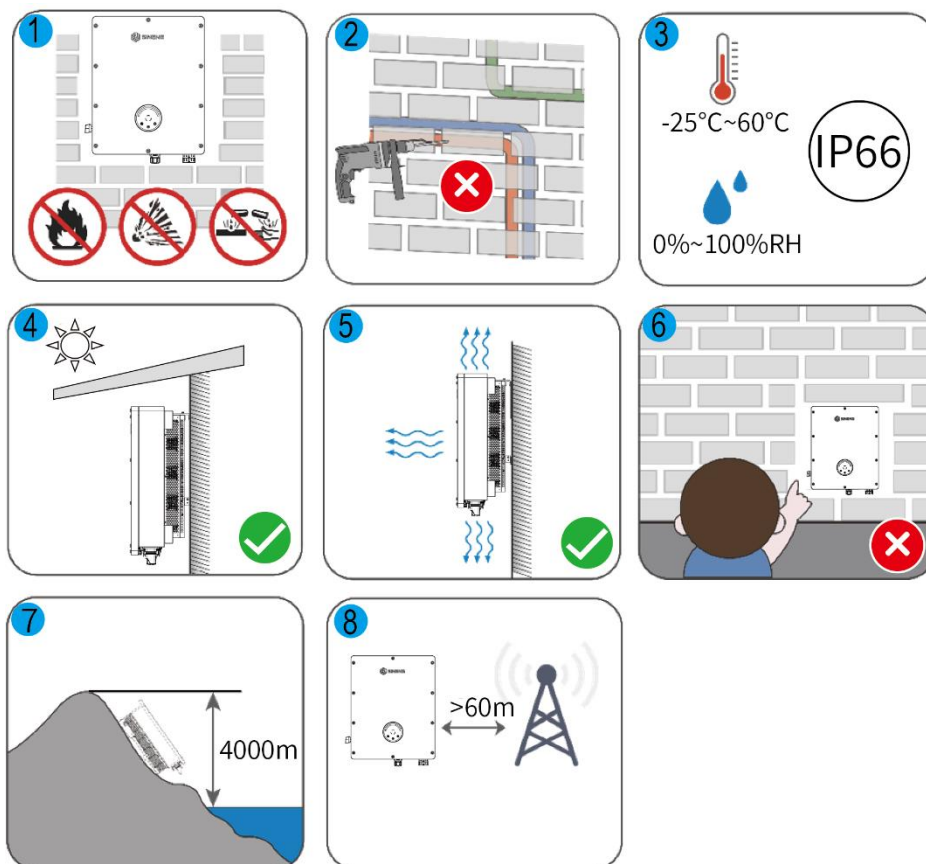

Figure 5-2 Requirements for installation environment

5.3 Installation Space Requirements

5.3.1 Installation of Single Inverter

When installing a single inverter, reserve sufficient space around the equipment to facilitate the installation, maintenance and heat dissipation of the inverter. The following figure shows the installation space of a single inverter.

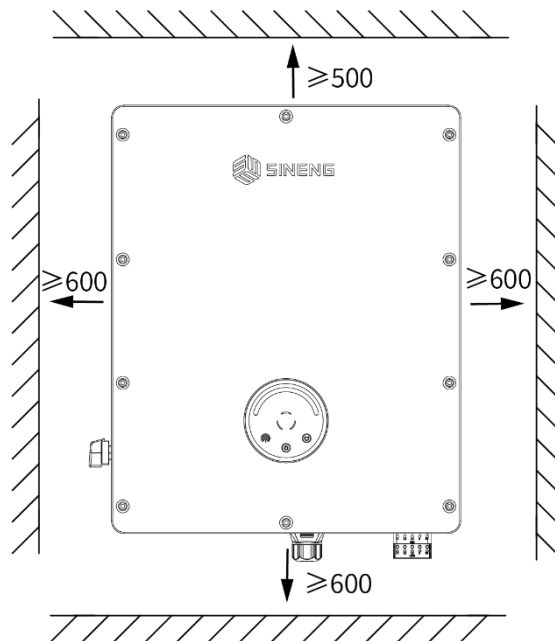

Figure 5-3 Schematic diagram of the installation space for a single inverter (Unit: mm)

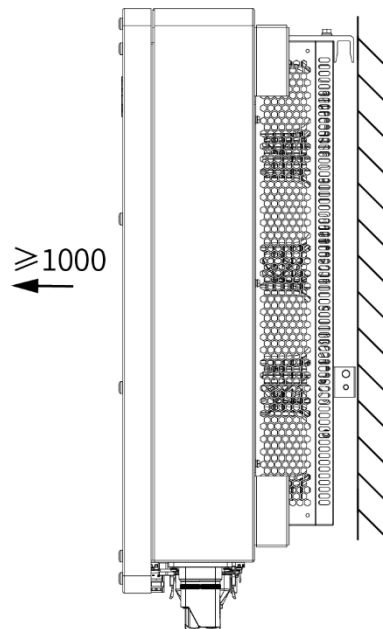

Figure 5-4 Schematic diagram of the installation space for a single inverter (Unit: mm)

5.3.2 Installation of multiple inverters

To ensure good heat dissipation and easy maintenance of the inverters, leave a proper distance between inverters. Generally, multiple inverters can be installed in a single-row side-by-side mode. In order to ensure power generation, multi-row staggered, back-to-back and wall-mounted installation method is not recommended. The specific installation requirements are described as follows.

Single-row side-by-side installation

When the inverters are installed side by side in a single row, the distance between the inverters is not less than 600mm. And the distance between the inverters and the upper, lower, left, and right solid objects (such as walls) should meet the spatial requirements for the installation of a single inverter, please refer to the following diagram.

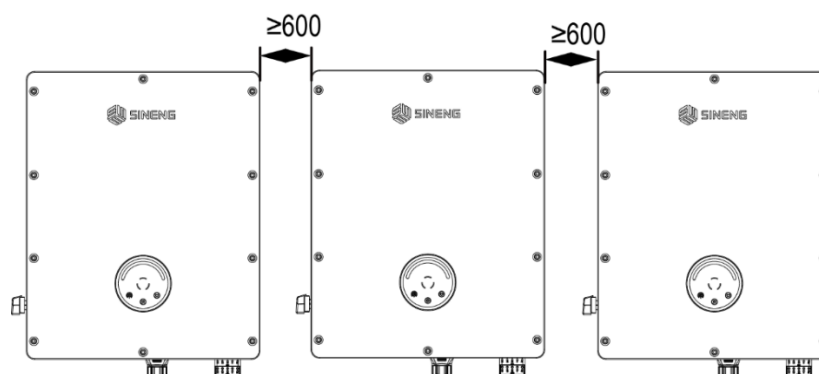

Figure 5-5 Single-row side-by-side installation (Unit: mm)

Multi-row staggered installation

To facilitate heat dissipation when installing multi-row inverters, there must be no intersection between two adjacent rows of inverters in the upper and lower spaces. The horizontal distance between two staggered inverters is not less than 350mm, and the vertical distance between the inverters is not less than 500mm. The distance between the inverters and the upper, lower, left, and right solid objects (e.g. walls) should correspond to the space required for the installation of a single inverter, as shown in the following diagram.

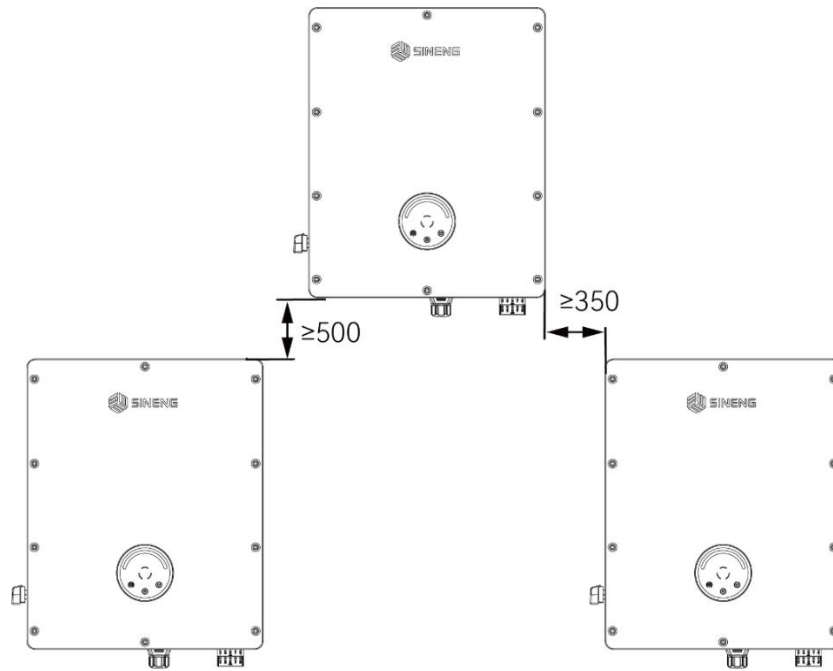

Figure 5-6 Multi-row staggered installation (Unit: mm)

5.4 Installation Angle Requirements

The following figure shows the recommended installation methods of the inverter.

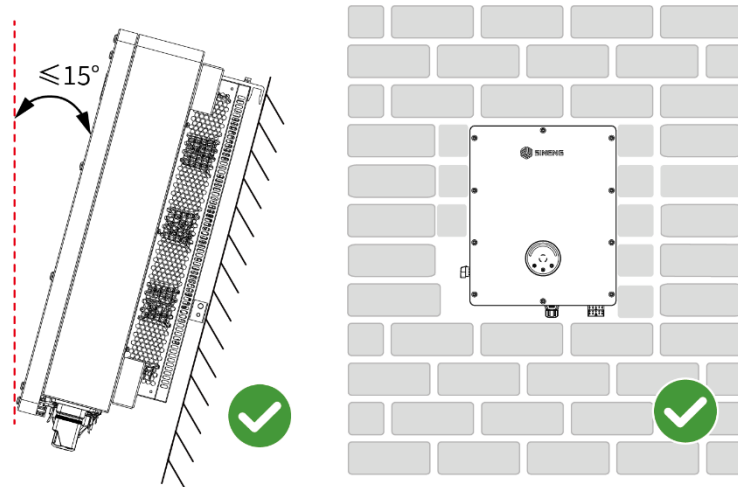

Figure 5-7 Correct installation

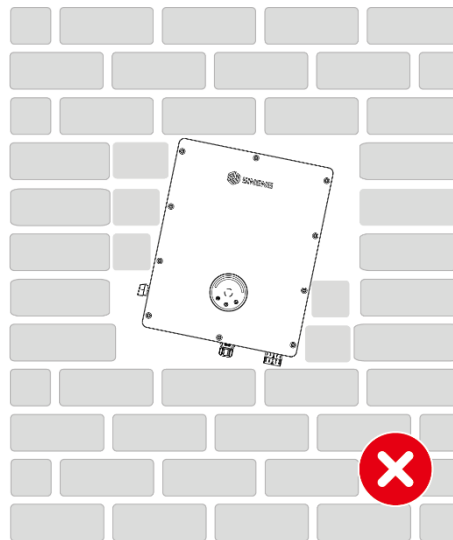

Figure 5-8 Incorrect installation

5.5 Installation Load-bearing Requirements

The installation carrier's load-bearing capacity must be at least 4 times the weight of the inverter and must match the size of the inverter.

It is prohibited to install the inverter on a carrier that may cause resonance.

5.6 Unpacking and Transportation



Warning

- Ensure that the inverter packaging is intact and undamaged before handling! If the packaging is damaged, please stop subsequent operations! In such a case, please contact Sineng or shipping company.
- Please read the instructions attached to the inverter package carefully before operation and pay attention to the warning signs on the inverter package!
- Because the inverter is heavy, no fewer than four persons are required for handling the inverter in manual handling mode. Keep balance when disassembling and handling the inverters to prevent personal injury caused by the falling of the inverters. When handling the inverter manually, please hold the support feet of the bottom chassis and the handles on both sides of the top side of the inverter. Prevent the bottom DC input terminals from colliding with other objects to avoid damaging the inverter housing and internal components. In addition, avoid squeezing or scratching the operators.
- When hoisting the inverter, please ensure that the hoisting tool is safe and reliable. During hoisting, you must always maintain a balance to avoid collisions with walls or

other obstacles. It is prohibited to hoist or store the equipment upside down!

- When the inverter is placed on the ground, cushioning materials such as foam or paper should be placed underneath the inverter to avoid damage to the bottom DC input terminals.

5.7 Installation of inverter



Caution

- Please avoid hitting the water pipes, cables, etc. in the wall to prevent danger when drilling holes.
- When drilling holes, please wear goggles and a dust mask to prevent dust from being inhaled or falling into your eyes
- Please prepare your own DC switch lock.

Procedure

Step 1 Determine the punching positions according to the inverter installation dimensions diagram shown in Figure 5-9.

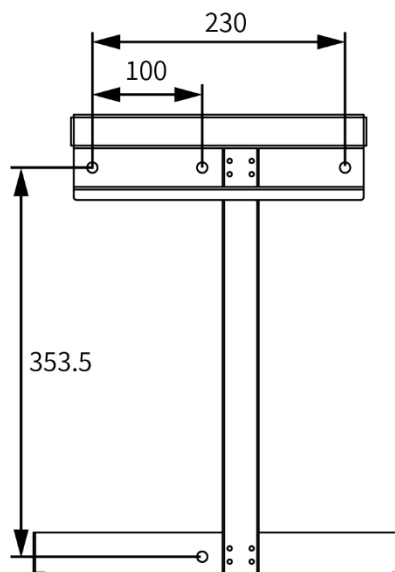

Figure 5-9 Making the puncturing area (Unit: mm)

Step 2 Take out the backplate from the accessories, use a level to ensure that the backplate is placed horizontally on the wall, and mark the drilling positions with a marking pen.

Step 3 Use a percussion drill with the drill bit diameter of 12mm to drill holes and ensure that the depth of the hole is about 70mm.

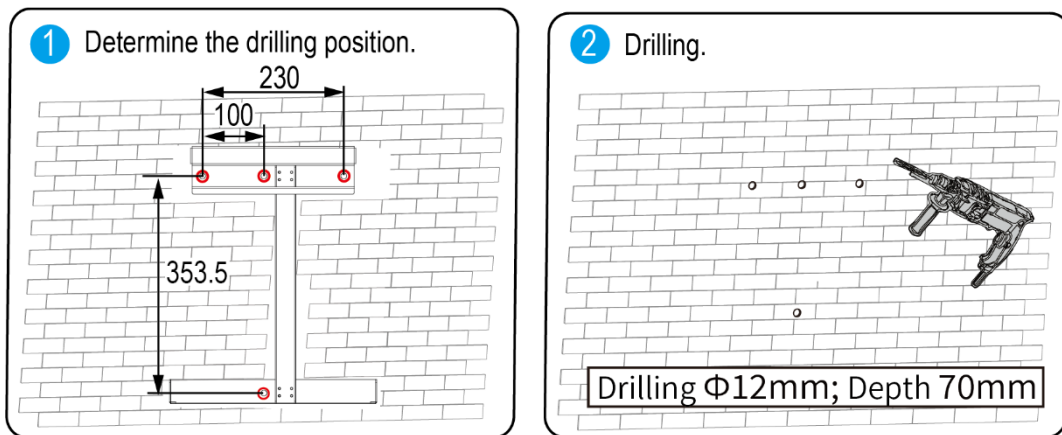

Figure 5-10 Drilling (Unit: mm)

Step 4 Install expansion tubes and fix the backplate to the wall with expansion bolts

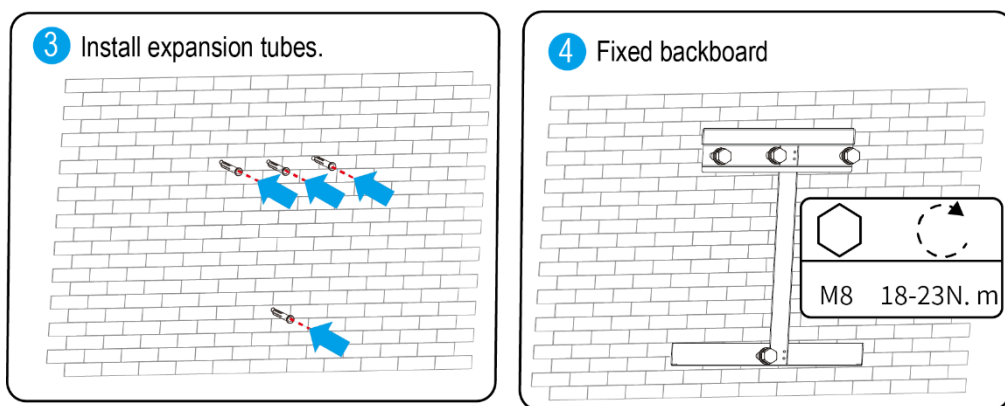

Figure 5-11 Fixed backboard

Step 5 Put out the inverter from the box.

Step 6 Hang the inverter on the backplate.

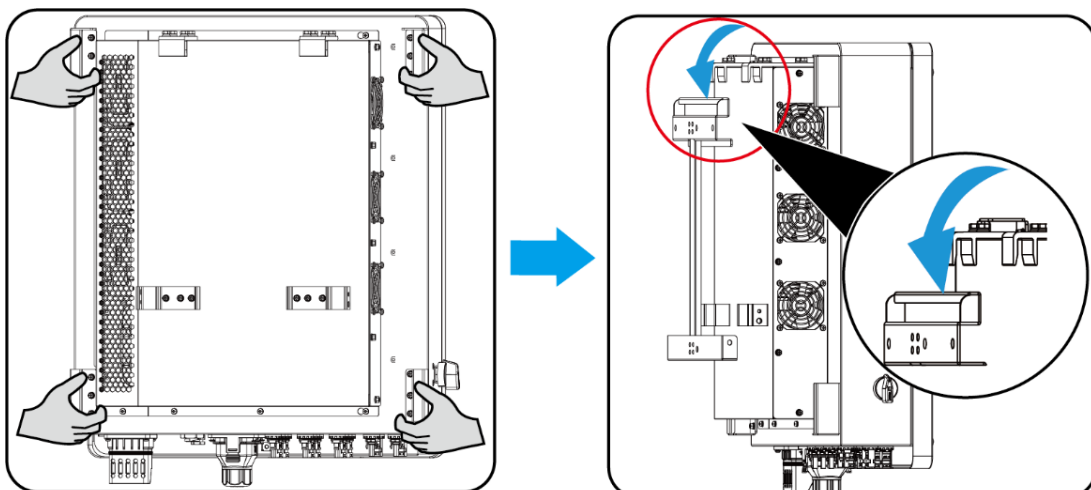

Figure 5-12 Hanging installation

Step 7 Install the screws of the back panel and L-shaped brackets.

Step 8 Place gaskets and tighten the expansion screws on the backplate at the bottom. Install anti-theft locks (if it is needed)

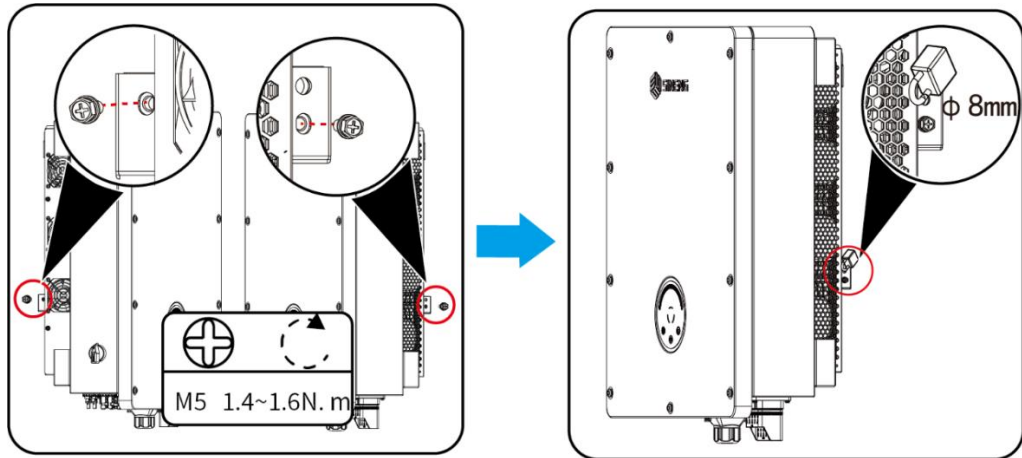

Figure 5-13 Installation of inverter

Chapter 6 Installing the Cables



Warning

- When there is light, a DC high voltage endangering the personal safety of the operator exists at the PV panel port!
- The insulation layer of the power cable must be intact and free from damages and scratches. Otherwise, it may cause short circuit or fire!
- Before cabling the inverter, check and confirm that all connection cables of the equipment have no dangerous voltage. Obvious warning signs must be set for the external power distribution switches of the equipment to avoid misoperation of the external switches, which could endanger the personal safety of the operator!
- Before wiring, ensure that the AC wiring port is disconnected from the power grid and the AC port has no voltage!
- Strictly follow the indications on the labels the inverter to connect the cables. Otherwise, it will cause damage to the equipment.
- The cable connections of the inverter must be safe and reliable. Cable selection and tightening torque must comply with the requirements of this manual. Otherwise, it may cause fire or damage to the inverter.

The external cables of the inverter include DC input cables, AC output cables, communication cables, and ground cables. Table 6-1 lists the cables and functions. Table 6-2 lists the cables that need to be prepared by customers.

Table 6-1 List of cables

Classification of Cables	Description	Remarks
Ground cable	Ground cable	Connecting to the nearest ground point
AC output cable	Connecting the box-type transformer and the AC output side of the inverter	Outdoor multi-core cable
DC input cable	Connecting the PV panel and the DC input side of the inverter	Multi-stranded input power cables
Communication cable	RS485 communication signal cable	Shielded cable

Table 6-2 Cable Specifications

Scenario	Type	Copper Wire	Fastening Bolt	Torque (N.m)
Grounding cable	Outdoor copper core cable	SN20~25HT: 10mm ² SN29.9~33HT: 16mm ²	M5 (OT)	1.4~1.6
AC cable (On-grid)	Outdoor copper core cable (5-core)	SN20~25HT: 10mm ² SN29.9~33HT: 16mm ²	\	2.4~2.6
AC cable (Off-grid)	Outdoor Copper core cable (5-core)	SN20~25HT: 10mm ² SN29.9~33HT: 16mm ²	\	2.4~2.6
DC input cable	Meet the standard for 1000V	4~6 mm ²	\	\
Battery input cable	Meet the standard for 1000V	10mm ²	\	\
Signal cable	\	0.5 mm ²	Cold terminals	\

6.1 Connecting the Ground Cable



Caution

- The inverter must be grounded reliably. Otherwise, it may cause personal injury or abnormal operation of the inverter!
- The inverter should be grounded at the nearest ground point. For multiple inverters connected in parallel in the same system, the protective ground cables of all inverters must be connected to the same ground busbar.

Procedure

Step 1 Crimping terminals.

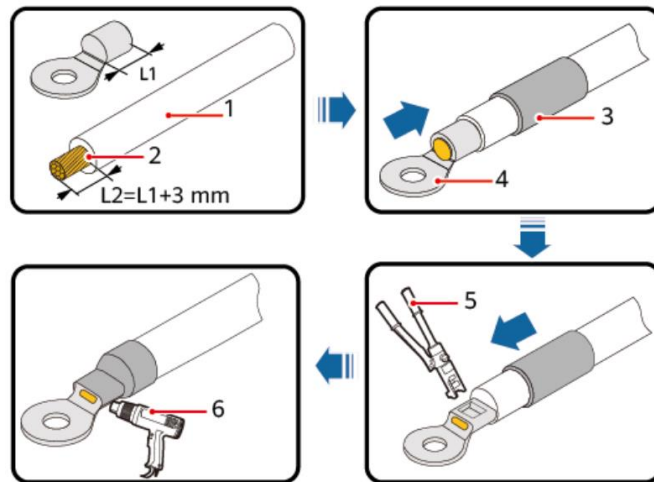

Figure 6-2 Crimping terminals

- | | | |
|---------------|--------------------|------------------------|
| 1 Cable | 2 Core | 3 Heat shrinkable tube |
| 4 OT terminal | 5 Hydraulic pliers | 6 Heat gun |

Step 2 Remove the screws on the ground point and install the ground cable using a Phillips screwdriver.

Step 3 Connect the other end of the cable to the main ground bar.

Step 4 After the ground terminal is tightened, apply silicone or outdoor paint on the outside of the terminal.

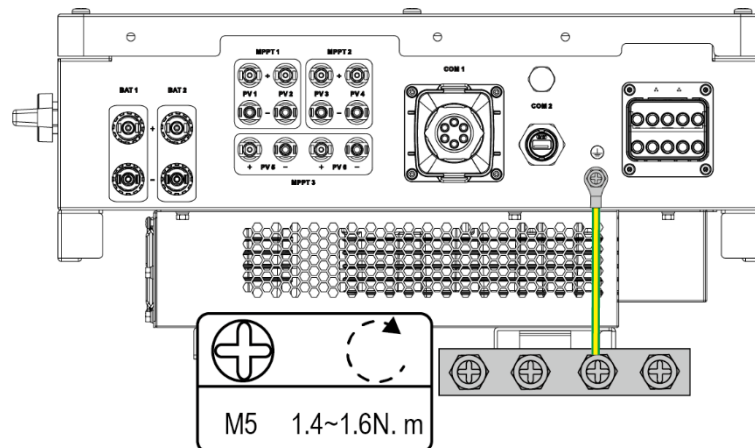

Figure 6-1 Schematic diagram of the protective ground cable installation

6.2 Connect AC cable(on-grid) and AC cable(off-grid)



Warning

- An AC circuit breaker matching the power of the inverter must be connected between the inverter's output and the grid, and each inverter corresponds to an independent circuit breaker!
- The on-grid and off-grid cable locks and fixing screws must be tightened, otherwise there is a risk of inverter damage or fire!
- When connecting on-grid and off-grid cables, make sure that the AC circuit breaker is disconnected!
- Inverters and AC circuit breakers are prohibited from connecting to loads!

To ensure that the SN series hybrid inverter is normally disconnected from the grid under abnormal conditions, please select a suitable AC circuit breaker. The recommended specifications are as follows:

Table 6-3 Recommended AC circuit breaker specifications

Inverter Model	Recommended AC Circuit Breaker Specifications
SN20HT	63A
SN25HT	63A
SN29.9HT	80A
SN30HT	80A
SN33HT	80A

The SN series hybrid inverter integrates a leakage protection circuit. If the leakage current is greater than the protection threshold value required by safety regulations, the inverter will automatically disconnect from the power grid.

Table 6-4 Recommended leakage current protection device specifications

Inverter Model	Trigger Value of Leakage Current
SN20HT	300mA
SN25HT	300mA
SN29.9HT	300mA
SN30HT	300mA
SN33HT	300mA

An AC output connector has three parts: coupler, adapter, and cable gland.

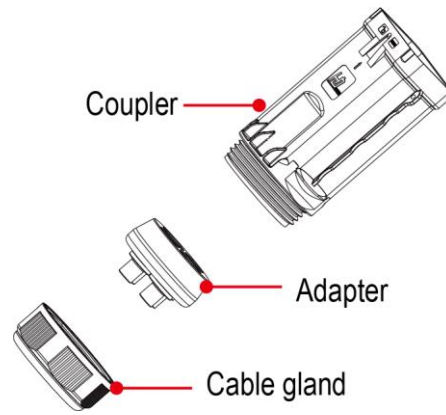

Figure 6-2 AC output connector

Procedure

- Step 1 Remove the cable gland and adapter from the AC output connector.
- Step 2 Remove an appropriate length of the jacket and insulation layer of the core wires from the AC output cable using a wire stripper.

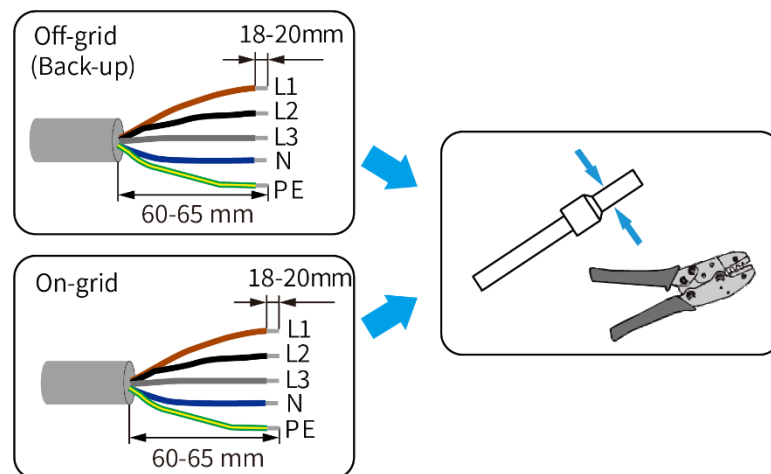

Figure 6-3 Making cables

- Step 3 Disassemble the AC connector, then insert the on-grid cables into the on-grid output terminal, and insert the back-up cables into the back-up output terminal.

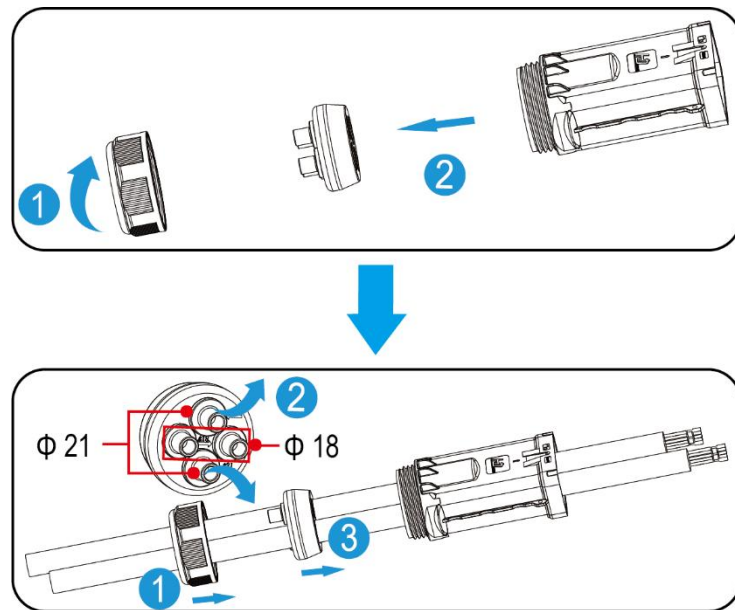

Figure 6-4 Making cables (Unit: mm)

**Note**

- For a 10mm² cable, it needs to be inserted through $\Phi 18$; for a 16mm² cable, it needs to be inserted through $\Phi 21$.

Step 4 Use a hex wrench to fix the AC cables. Connect the AC output terminal and the inverter.

**Note**

- Make sure that the protective layer of the cable is inside the connector, otherwise it will reduce the sealing level at the terminal.
- When fixing the cables, ensure that the cores are fully inserted into the wiring holes without exposure.

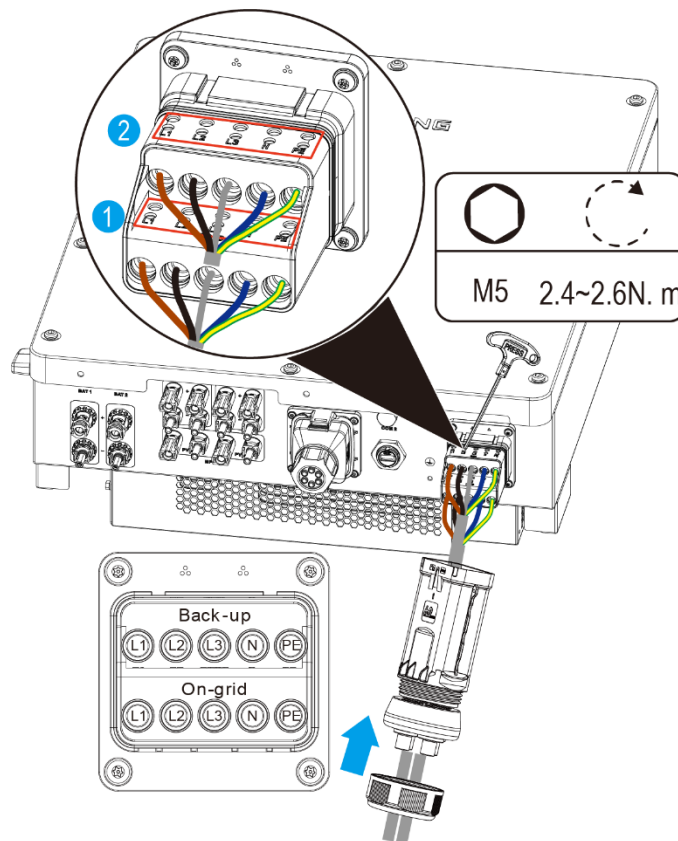

Figure 6-5 Install AC cable

6.3 Connecting the DC Power Cable



Warning

- If PV modules are exposed to light, the photovoltaic panel may endanger the life of the operator with high voltage output!
- Before wiring, make sure that the side of the photovoltaic panel is completely covered with an opaque cloth before the operation.
- The DC switch of the inverter must be in the "OFF" position!
- If the inverter is directly connected to the grid, the positive and negative poles of the photovoltaic panel cannot be directly grounded.
- If multiple inverters are connected in parallel to the grid through a transformer, the positive and negative poles of the photovoltaic panel cannot be directly grounded.
- It is forbidden to use DC terminals with specifications, models, and brands other than those provided by us!
- Before connecting the photovoltaic strings to the inverter, ensure that the photovoltaic strings are well insulated from the ground!
- To increase the power generation capacity of the system, it is recommended that each

string be connected with the photovoltaic strings with the same number, specifications, and direction!

Procedure

- Step 1 Turn the DC switch to the "OFF" position.
- Step 2 Strip the cable insulation skin to a suitable length using a wire stripper, put it into the corresponding metallic terminal, and use crimp it tightly using a special crimping tool.
- Step 3 Insert the crimped positive and negative cables into the corresponding insulation housing respectively.
- Step 4 Insert the cable until you hear a "click", indicating that the cable is clamped into place.
- Step 5 Turn to tighten the plastic nuts at the end of the insulation housing of the positive and negative connectors.
- Step 6 Measure the correctness of the positive and negative polarities of the positive and negative connectors using a multimeter. Measure the maximum voltage of the positive and negative electrodes and ensure that it meets the requirements, which should be lower than 1000 V.
- Step 7 Remove the dust-proof plug from the DC input terminal, and insert the positive and negative connectors into the positive and negative electrodes of the DC input terminal of the inverter until you hear a "click", indicating that the connectors are installed in place.
- Step 8 Connect other PV strings according to the above steps.

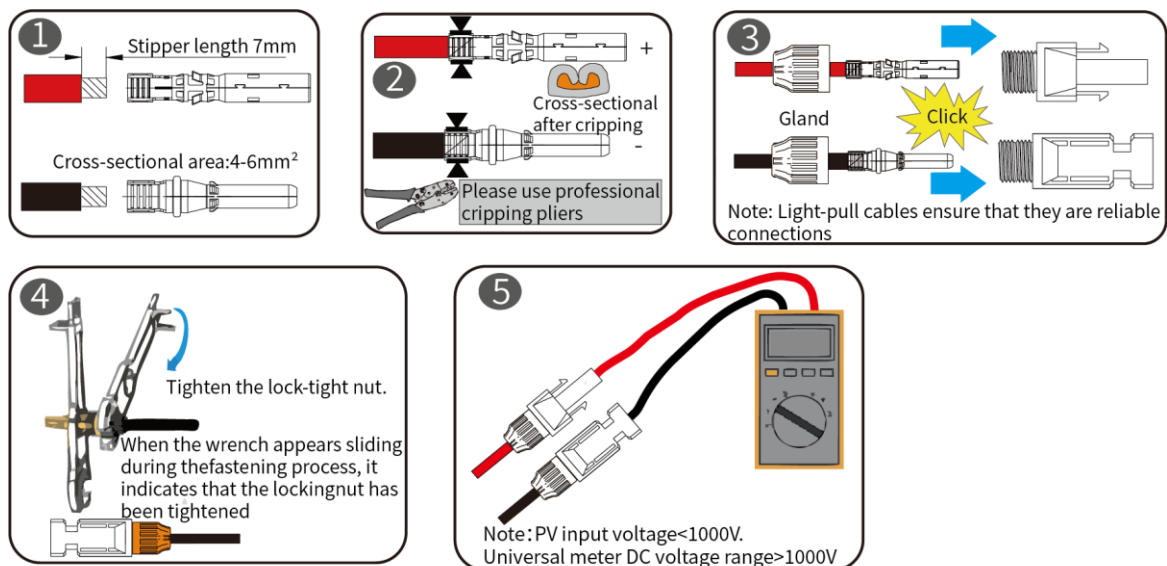

Figure 6-6 Connecting the DC Power Cable



Note

- It is prohibited to use PV connectors not provided by Sineng.
- It is prohibited to remove the dust plugs from unused DC input terminals.
- It is prohibited to plug or unplug the energized PV connector.
- Before plugging or unplugging PV connectors, the DC switch must be turned to the "OFF" position.

Step 9 Bind the DC power cables to the beam.

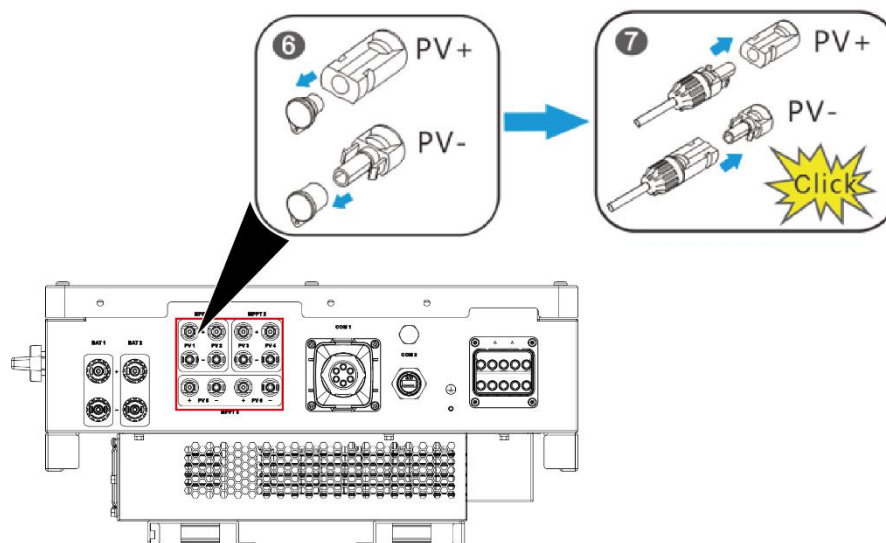

Figure 6-7 PV input terminal

6.4 Connecting Battery Input Cable



Note

- The wiring method for the battery connection and DC connections is similar, except for the different colors of the terminals: the battery connector is blue, while the DC connector is black. When the terminal is inserted into the machine, please make sure the insertion is correct.
- When wiring, make sure that the polarity of the battery cable is correct, and do not reverse it. If the positive and negative poles of the battery get reversed, there is a risk of damaging the inverter.

Procedure

Step 1 Turn the DC switch to the "OFF" position.

- Step 2 Strip the cable insulation skin to a suitable length using a wire stripper, put it into the corresponding metallic terminal, and use crimp it tightly using a special crimping tool.
- Step 3 Insert the crimped positive and negative cables into the corresponding insulation housing respectively.
- Step 4 Turn to tighten the plastic nuts at the end of the insulation housing of the positive and negative connectors.
- Step 5 Measure the correctness of the positive and negative polarities of the positive and negative connectors using a multimeter. Measure the maximum voltage of the positive and negative electrodes and ensure that it meets the requirements, which should be lower than 800V.

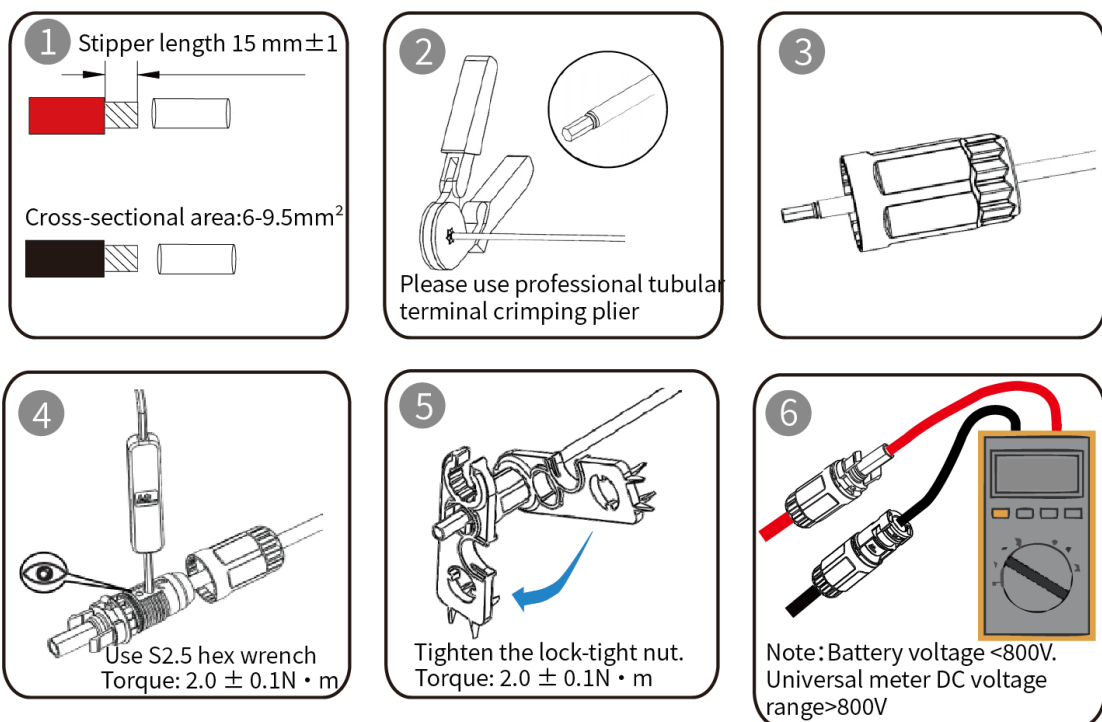

Figure 6-8 Connecting the battery input cable

- Step 6 Remove the dust-proof plug from the battery input terminal, and insert the positive and negative connectors into the positive and negative electrodes of the battery input terminal of the inverter until you hear a "click", indicating that the connectors are installed in place.
- Step 7 Connect other BAT strings according to the above steps.
- Step 8 Connect the battery input cable.

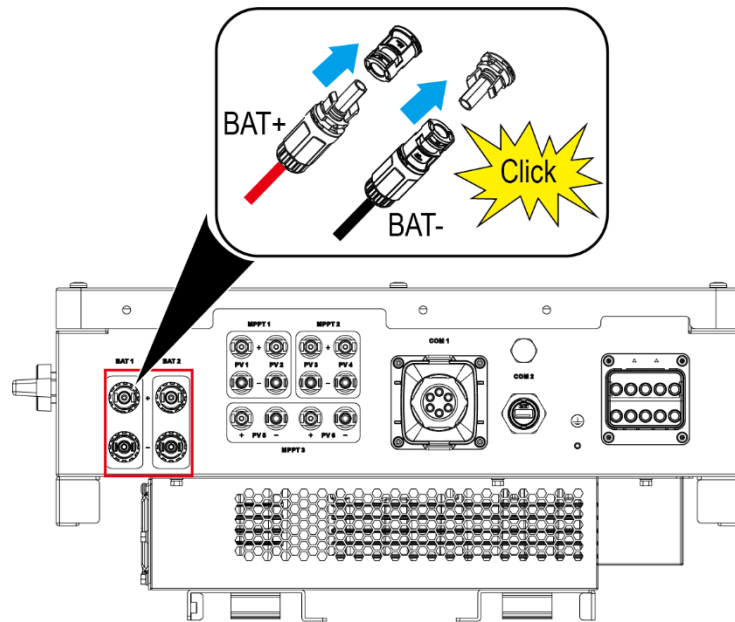

Figure 6-9 Connect the battery input cable

6.5 Install Communication module



Caution

- When installing the communication module, the three indicator lights should face outward.
- When installing the communication module, it is forbidden to rotate the WIFI module, which may result in loose terminals on the panel end and cause water to enter the inverter.
- To install the communication module, please tighten the plastic nut clockwise, otherwise there will be a risk of abnormal communication or water ingress.

Procedure

Step 1 Unscrew the dust-proof cover of the aviation plug, insert the communication module into the data acquisition stick terminal, and tighten the plastic nut clockwise.

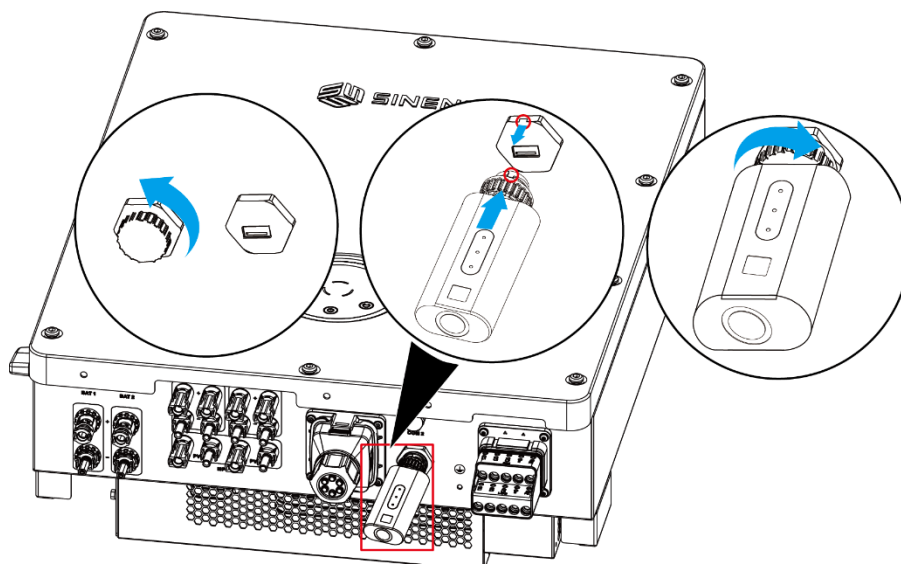

Figure 6-10 Install the Communication module

Note: When inserting, the boss on the communication module should be aligned with the groove on the USB base.

6.6 Install the Communication cable

Making cable

Step 1 Remove an appropriate length of the jacket and insulation layer of the core wires from the communication cable using a wire stripper.

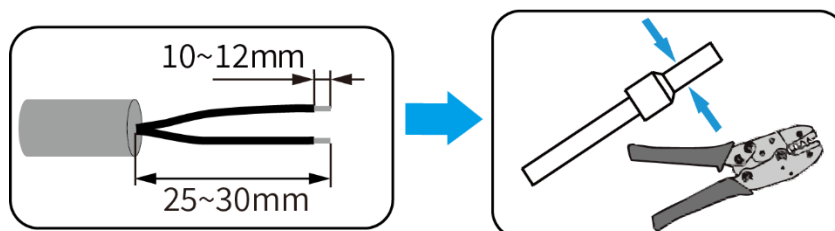

Figure 6-11 Making cable

Step 2 Disassemble connector.

Step 3 Route the cables through the lock nut, the main body, and then crimp the signal cable.

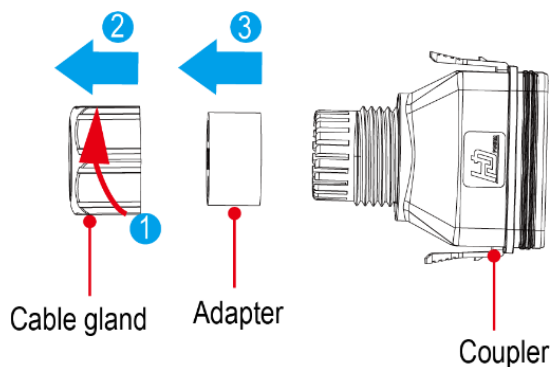

Figure 6-12 Communication cable connector has three parts

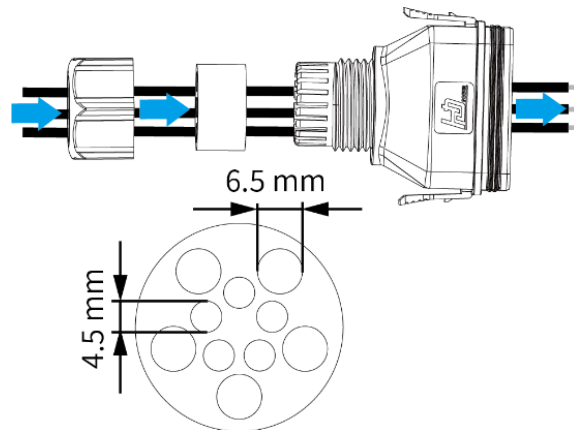

Figure 6-13 Threading

Note: RJ45 wires are recommended to use diameter 6.5mm holes AWG 22 wires are recommended to use diameter 4.5mm holes.

6.6.1 Install Dry contact cable

Procedure

- Step 1 Press the contact plate using a flat-head screwdriver to flip the metal spring inside each dry contact.
- Step 2 Connect the signal cables to the corresponding dry contacts.
- Step 3 Put away the flat-head screwdriver and check that the signal cables are securely connected

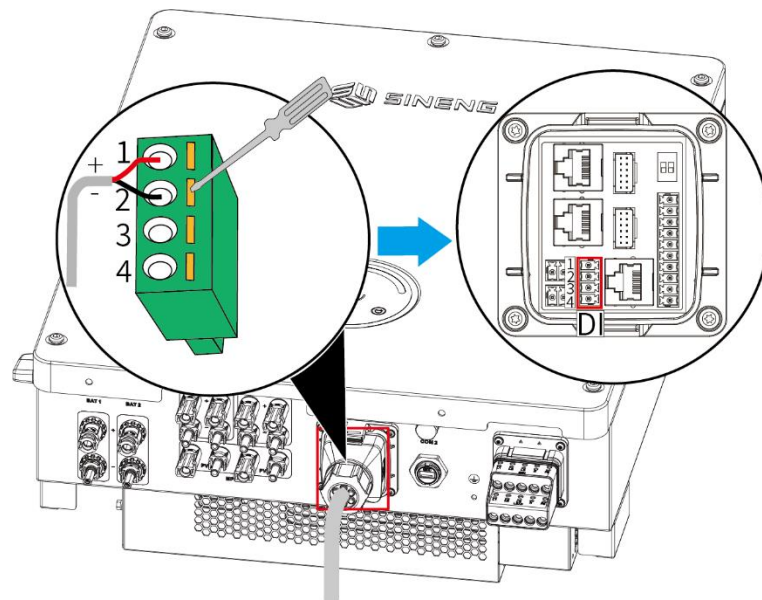
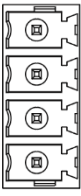

Figure 6-14 Install DI dry contact cable

Port appearance	Name	PIN	Meaning
	DI	1	DI_OUT1
		2	GND
		3	DI_OUT2
		4	GND

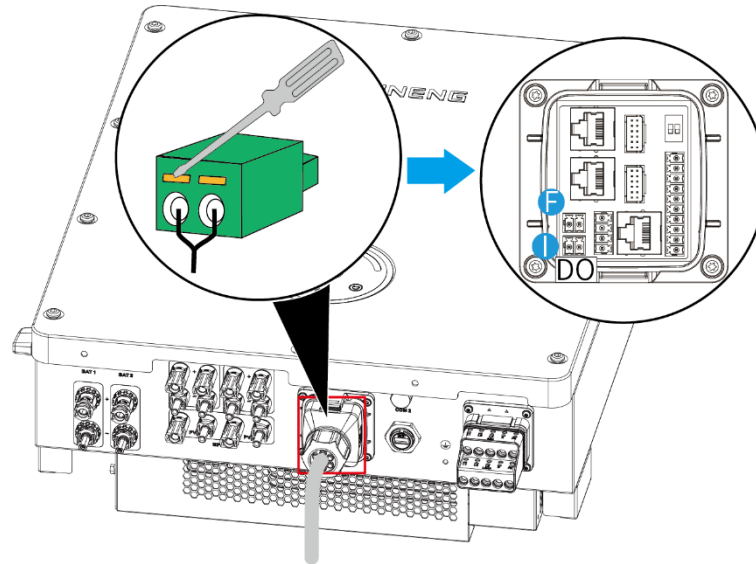
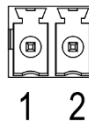

Figure 6-15 Install DO dry contact cable

Port	Port appearance	Name	PIN	Meaning
F		DO	1	DO_NO_2
			2	DO_COM_2
I		DO	1	DO_NO_1
			2	DO_COM_1
Note: The diameter of DO cable must be greater than 0.5mm ² . The pressure resistance level needs to be greater than 500V.				

6.6.2 Connect BMS/DRM communication cable

Context

BMS: The communication cables of the battery shall correspond to the power cables. When the power cable is connected to BAT1, the communication cable shall be connected to BMS1; when the power cable is connected to BAT2, the communication cable shall be connected to BMS2. If the battery adopts the dual parallel mode, only one set of communication cables needs to be connected, and **Enable** the corresponding BAT on the APP.

DRM:

In single-unit mode, simply connect the RJ45 cable.

In parallel mode, cascade the DRM ports of all inverters and connect the RJ45 cables in a **daisy chain** configuration.

- With an internal resistance less than or equal to 1.5 ohms/10 m
- With an outer diameter of 4.5-7.5 mm (8 core wires, each with a diameter of 1.00-1.07 mm)

Procedure

Step 1 Remove an appropriate length of the insulation layer from the shielded network cable using a wire stripper.

Step 2 Line up the exposed wires of the network cable in sequence and connect them to the corresponding pins on the plug.

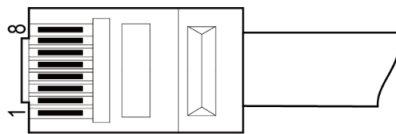

Figure 6-16 Connection sequence

PIN	Colour	Description (BMS)	Description (DRM)
1	White-orange	NC	GND
2	Orange	NC	+5V
3	White-green	NC	COM/DRM0_OUT
4	Blue	CAN_H_BMS	DRM1/5_OUT
5	White-blue	CAN_L_BMS	DRM2/6_OUT
6	Green	NC	DRM3/7_OUT
7	White-brown	NC	DRM4/8_OUT
8	Brown	NC	DRM_COM

Step 3 Connect the communication cable.

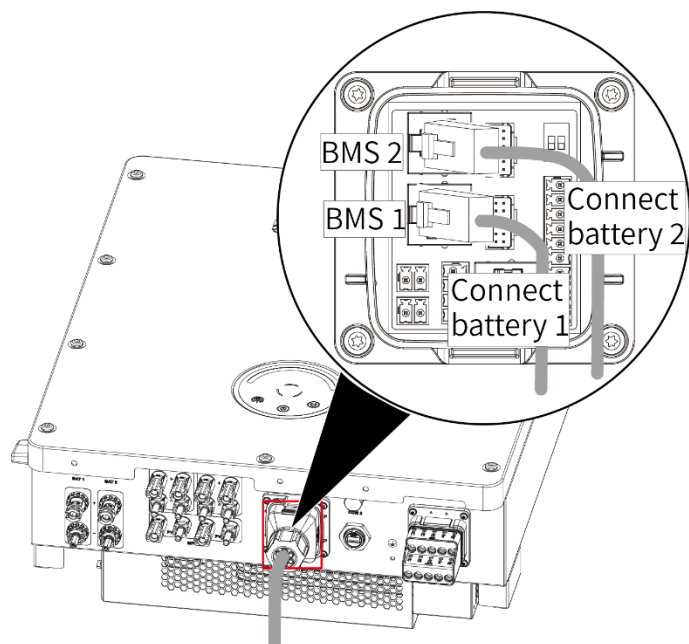

Figure 6-17 Connect BMS signal cable

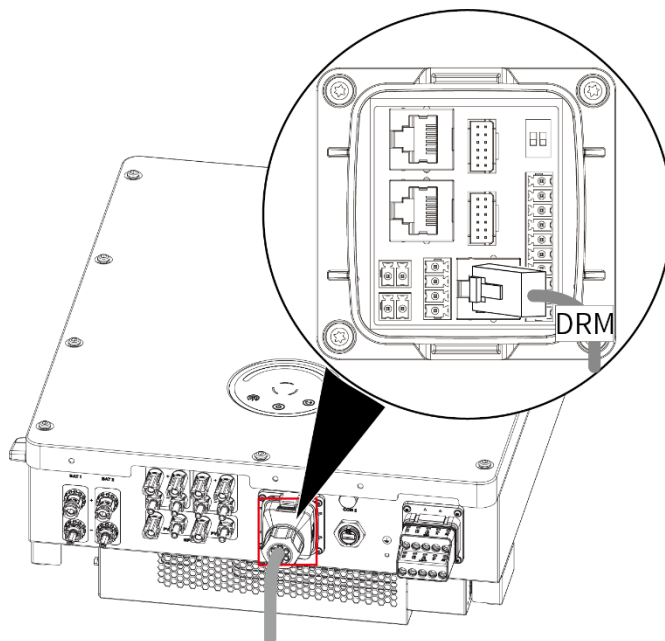

Figure 6-18 Connect DRM signal cable

6.6.3 (Optional) Install Parallel signal cables

Procedure

Step 1 Install the RS485 parallel cable.

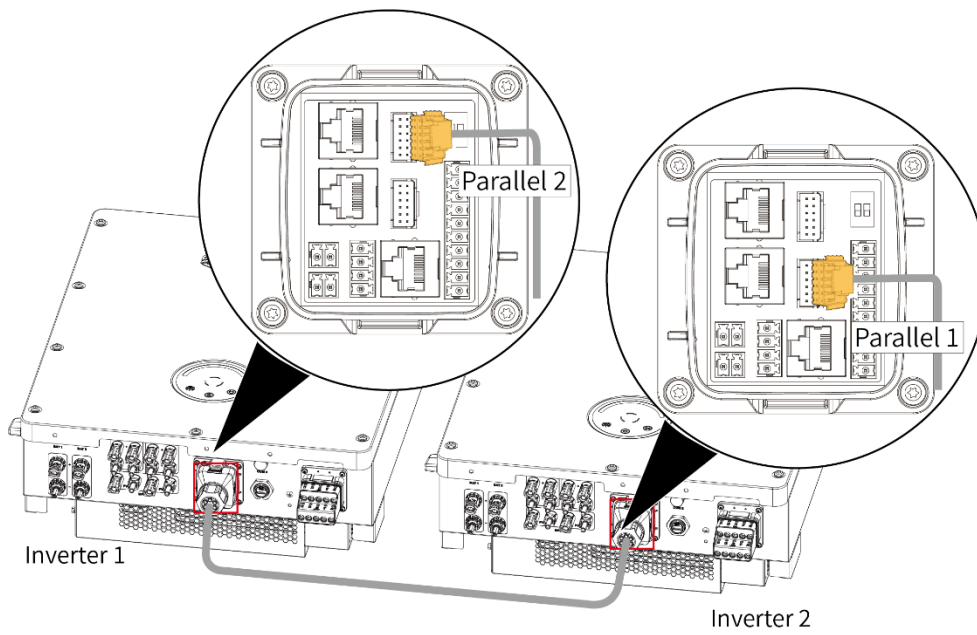

Figure 6-19 Install parallel signal cables (2 parallel machines)

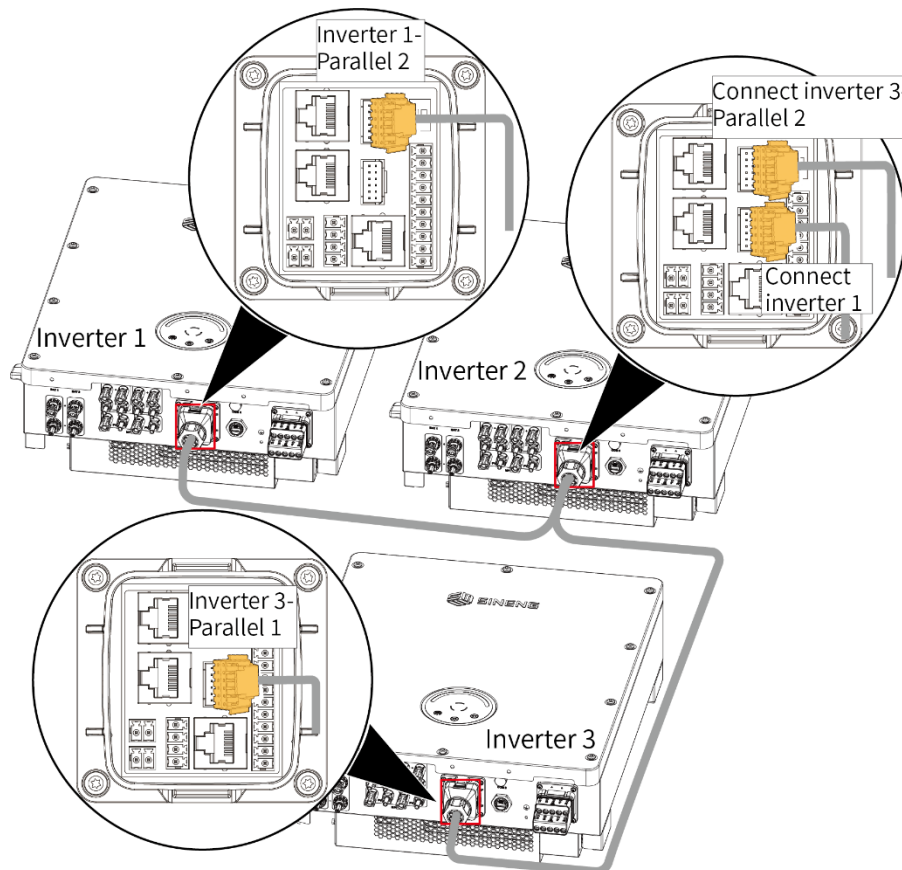

Figure 6-20 Install parallel signal cables (3 parallel machines)

Step 2 Set the DIP switch.

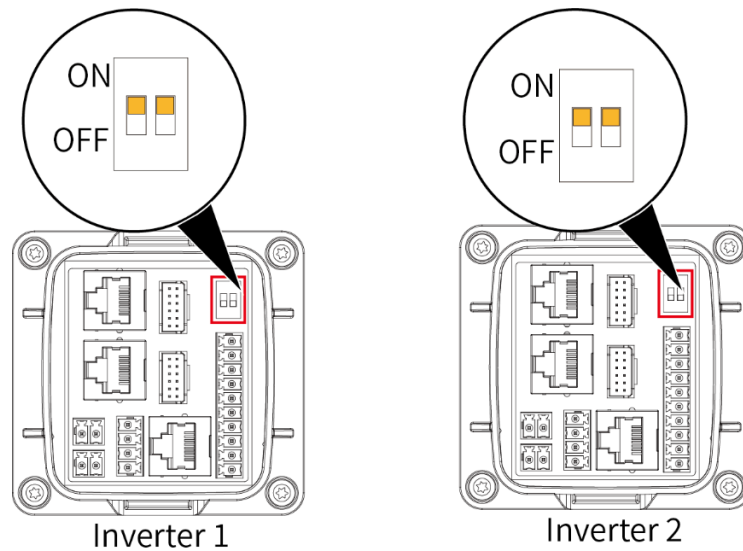

Figure 6-21 DIP Switch Status for 2 parallel machines

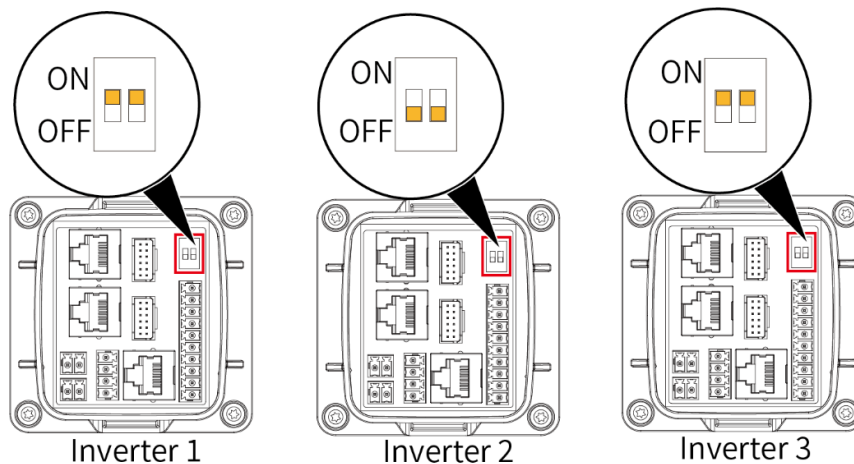

Figure 6-22 DIP Switch Status for 3 parallel machines

6.7 Smart Meter and CT Connection

The Smart Meter with CT in the SN product box is compulsory for the system installation and it is used to detect grid voltage, current direction, and magnitude, as well as to instruct the operation condition of inverter via RS485 communication.



Caution

- Make sure AC cable is totally isolated from AC power before connecting Smart Meter & CT.
- The Smart Meter and CT is well configured, please do not change any setting on Smart Meter.
- For more detailed instructions, please refer to the user manual included with the smart meter.

- Please use the Smart Meter with CT in the SN product box.
- CT cable is 3m as default, which could be extended to 5m at maximum.
- When installing the Smart Meter, ensure that the current direction is the same as the arrow direction on the Smart Meter.

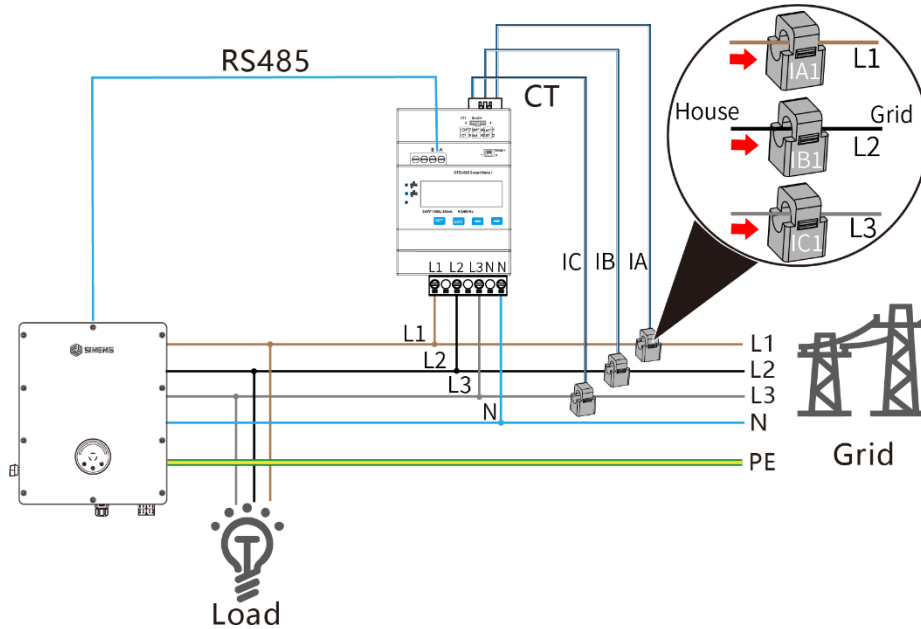

Figure 6-23 Smart Meter & CT Connection Diagram

Procedure

- Step 1 Press the contact plate using a flat-head screwdriver to flip the metal spring inside each dry contact.
- Step 2 Connect the signal cables to the corresponding dry contacts.
- Step 3 Put away the flat-head screwdriver and check that the signal cables are securely connected.

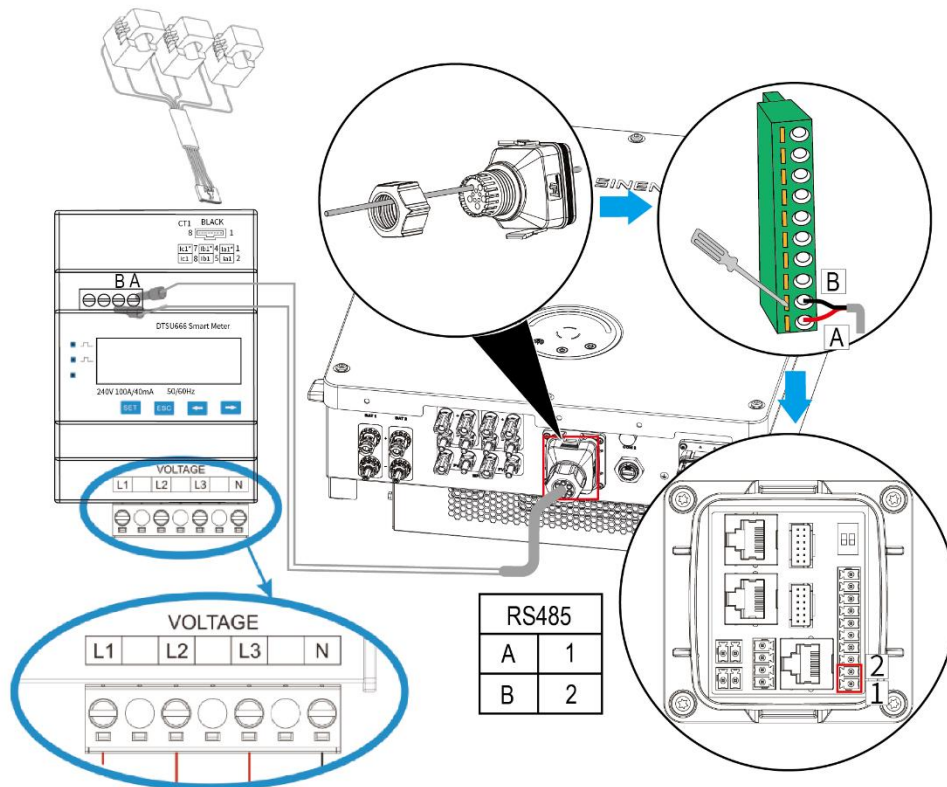

Figure 6-24 Smart meter and CT connection

Port	Port appearance	Name	PIN	Meaning
C		RS485	10	+5V
			9	GND
			8	485_A_MULT
			7	485_B_MULT
			6	GND
			5	+12V OUT
			4	Reserve
			3	Reserve
			2	485_B_METER
			1	485_A_METER

Chapter 7 Check after Installation

Table 7-1 Check items

SN	Check Item	Check Result (Yes \checkmark / No \times)
1	Check whether the DC switch of the inverter is in the "OFF" position.	<input type="checkbox"/>
2	Check whether the inverter installation is firm and reliable.	<input type="checkbox"/>
3	Check whether the connection of the external grounding cable is correct, whether the terminal is tight, whether the grounding is reliable, and ensure that there is no open circuit or short circuit.	<input type="checkbox"/>
4	Check whether the AC output cables are connected correctly, whether the terminals are fastened, and ensure that there is no open circuit or short circuit.	<input type="checkbox"/>
5	Check whether the polarity of the DC input cable is correct, whether the connector insertion is firm, and ensure that there is no open circuit or short circuit.	<input type="checkbox"/>
6	Check whether the connection of the communication cable is correct, whether the terminal is tight, and ensure that there is no open circuit or short circuit.	<input type="checkbox"/>
7	Check whether the plastic nut on AC side and those at the end of the communication cable lock are tightened.	<input type="checkbox"/>
8	Check whether the unused ports are fitted with dust plugs.	<input type="checkbox"/>
9	Check whether the data acquisition stick module is installed correctly (only for products with optional data acquisition stick).	<input type="checkbox"/>



Caution

- Multi-point grounding in the matrix is prohibited!
- If everything is normal for the temperature of the direct connection terminal, it means that the connection of the DC terminal is reliable.

Chapter 8 Power-On/Off



Warning

- For the inverter that has been shut down for a long time, comprehensively and carefully inspect the equipment before starting it up to ensure that all indicators meet the requirements.
- Only professional personnel are allowed to operate the inverter. Others cannot operate it without authorization.
- Ensure that the circuit breaker of the box-type transformer connected to the AC side of the inverter is in the open state.
- Ensure that the DC switch is turned to the "OFF" position.

8.1 Power-On

Procedure

Step 1 Check whether the electrical connection is correct.

Step 2 Close the DC switch.

Step 3 Power on the grid side.

Step 4 Power on the PV side.

Step 5 Power on the battery side.

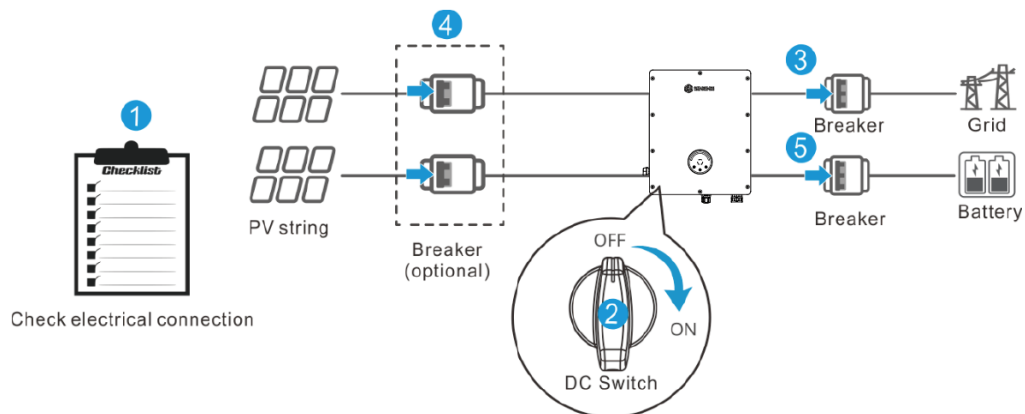

Figure 8-1 Power-On



Note

- To keep the inverter in normal operating condition, there are specific requirements for the connection method of the smart meter, and the smart meter certified or supplied by us should be used.

- Pay attention to the direction of the power flow when connecting the smart meter. The power is negative when drawing power from the grid, and positive when sending power to the grid.
-

8.2 Power-Off

Procedure

Step 1 Turn of the DC switch.

Step 2 Turn off the AC switch between the inverter and the power grid.

Step 3 Turn of the battery side switch.



Warning

- For the inverter that has been shut down for a long time, comprehensively and carefully inspect the equipment before starting it up to ensure that all indicators meet the requirements.
 - After the inverter powers off, the remaining electricity and heat may still cause electric shocks and body burns. Therefore, put on protective gloves and begin servicing the inverter five minutes after the power-off.
-

Chapter 9 Power Insight App

For details, please refer to the *Enjoy Solar Smart Energy Management Platform O&M Manual For APP (User)*.

For details of the PowerInsight APP, please refer to the "Si-Dongle-0~Z Quick Installation Guide" .

9.1 Downloading the App

- China: The app is available in Huawei, Xiaomi, OPPO, VIVO, 360 and Apple App Stores.
- Other regions and countries: The app is available in Google Play and App Store.
- The app supports Android 6.0 and later versions or iOS 12 and later versions.
- EnjoySolar (Online monitoring)
- PowerInsight (Local configuration)



Figure 9-1 QR code for downloading EnjoySolar App



Figure 9-2 QR code for downloading PowerInsight App

9.2 Registration

Procedure

Step 1 Open app and enter login screen, tap Register to enter the registration screen.



EnjoySolar

Enter username/phone/email

Please enter the password

Remember Password Password Forq

I have read and agree [《T&Cs》](#) And [《Privacy Policy》](#)

Login

Register

Figure 9-3 App Login

Step 2 Select the registration mode, you can register by mobile number or email.

- Phone number login

Enter your phone number, select a country or region, and obtain a verification code.

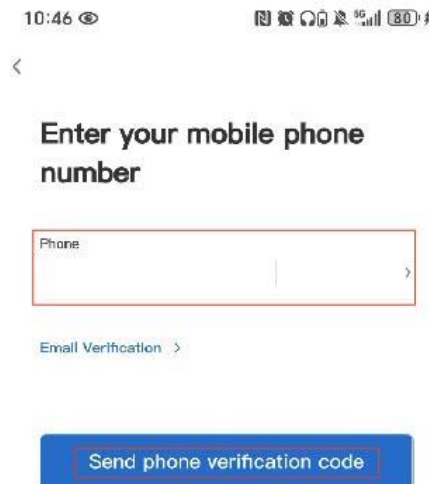

10:46

Enter your mobile phone number

Phone

Email Verification >

Send phone verification code

Figure 9-4 Obtain verification code

- Email login

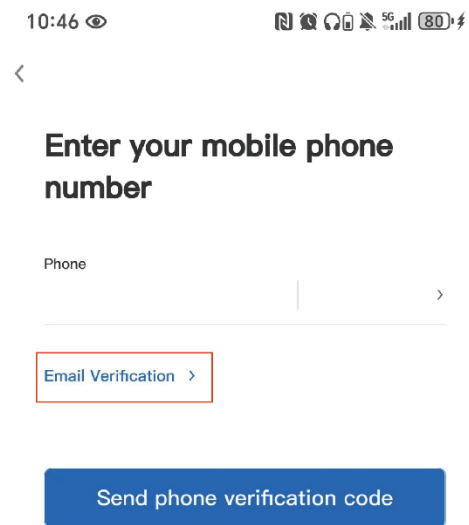

Figure 9-5 Email login 1

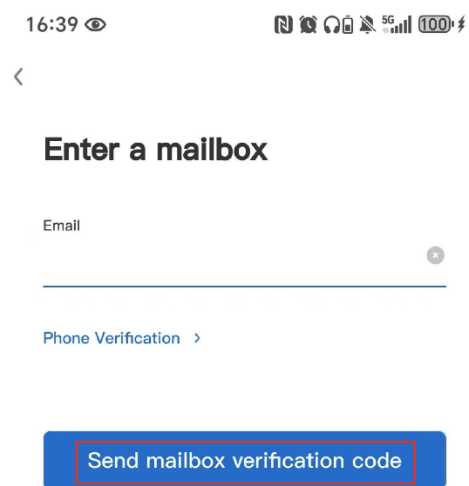

Figure 9-6 Email login 2

Step 3 Enter the verification code and click confirm.

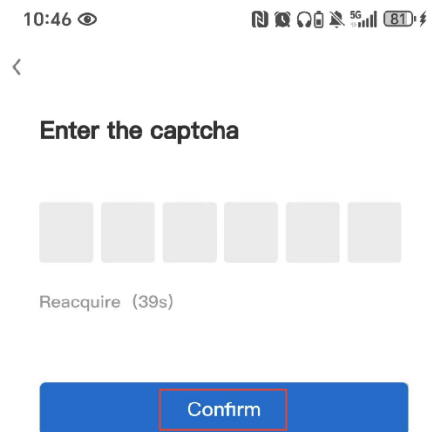

Figure 9-7 Enter verification code

Step 4 Fill in the user name, password, and confirm password.

Step 5 After the system prompts for successful registration, go back to the **Login** screen.

9.3 Login

Procedure

Step 1 Open Enjoy Solar app. Enter the Login screen.

Step 2 Enter the account number and password.

Step 3 Select I have read and agree [《T&Cs》](#) And [《Privacy Policy》](#) .

Step 4 Tap **Login**. The home screen is displayed after you log in successfully.



Note

- If you check **Remember password**, the app will automatically remember the password within 5 days after the account is successfully logged in.

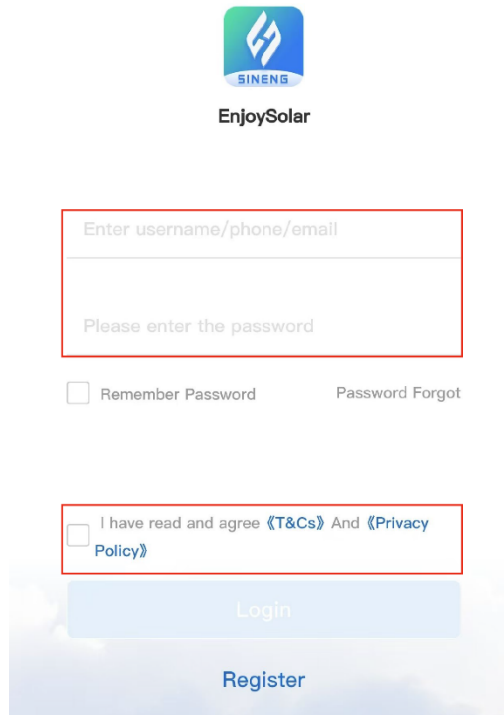

EnjoySolar

Enter username/phone/email

Please enter the password

Remember Password Password Forgot

I have read and agree [《T&Cs》](#) And [《Privacy Policy》](#)

Login

Register

Figure 9-8 Login

9.4 Logout

Procedure

Step 1 On the premise that you are logged in, tap **Logout** on the **Me > Settings** screen.

Step 2 The app normally exits to the **Login** screen.

9.5 Running mode

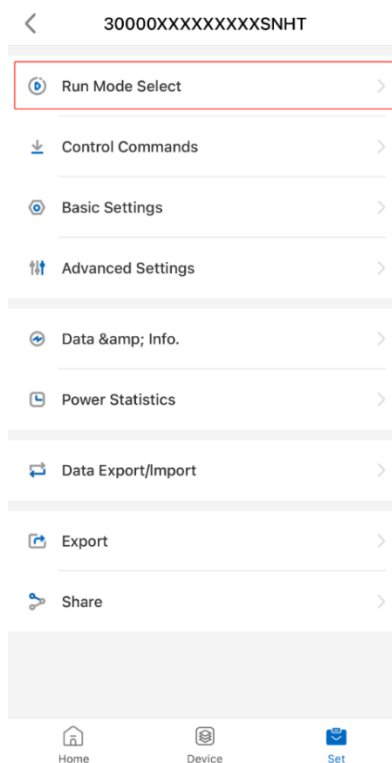

Figure 9-9 Run mode select

9.5.1 Self-use mode

Prioritized order of energy self-use

PV priority: The PV-generated electricity is supplied to the load first while the surplus is supplied to charge the battery, and any remaining electricity, if any, is sent selectively to the grid.

When the battery is discharging:

On-grid min. SOC setting range: 10-100%.

Normal charging and discharging is allowed at $SOC_{cur} > SOC_{min}$. The battery stops discharging until $SOC_{cur} < SOC_{min}$.

Force charge the battery when the SOC_{cur} is below 9% until the SOC rises to 14%.

Winter forced charging option

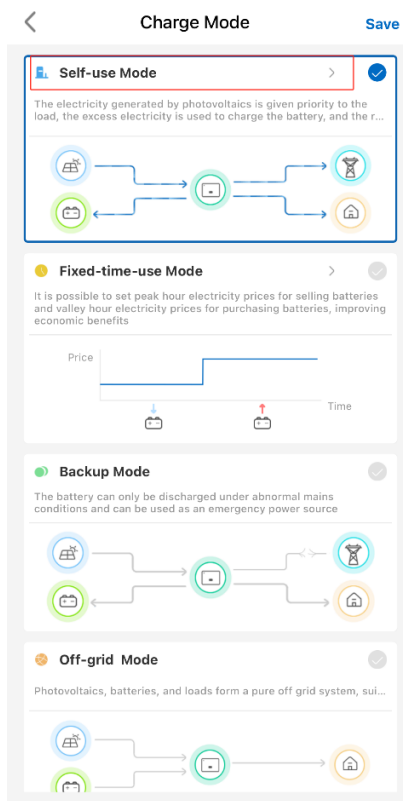

Figure 9-10 Winter forced charging option

Parameter	Description
Forced charging function enabled	Enabled: Enable this function Disabled: Disable this function.
Start date and time	The date and time when the forced charging function starts.
End date and time	The date and time when the forced charge ends. Note: If the end date is later than the start date, they are considered to be in the same year. If the end date is earlier than the start date, the date is considered to span the year, counting first from the start date to 31 December, then from 1 January to the end date.
Time	It must not span days, and the end time must be later than the start time. Otherwise, the setting will fail.
Power	The power for forced charging of the battery
SOC	Charge to a value where SOC stops charging.
Week function	Set the day of the week on which the battery is to be intensively charged.



Note

- The actual charging power is affected by the PV, the rated power based on the model, the battery charging limit value and whether the battery can be charged from the mains.
- The power is the minimum value of the PV, the rated power and the battery charge limit.

9.5.2 Fixed-time-use Mode

Overview

We can set a peak power price to sell power from batteries and buy power for batteries at an off-peak power price, which can improve the economic benefits.

The equipment can automatically switch to off-grid mode, when the power grid fails.

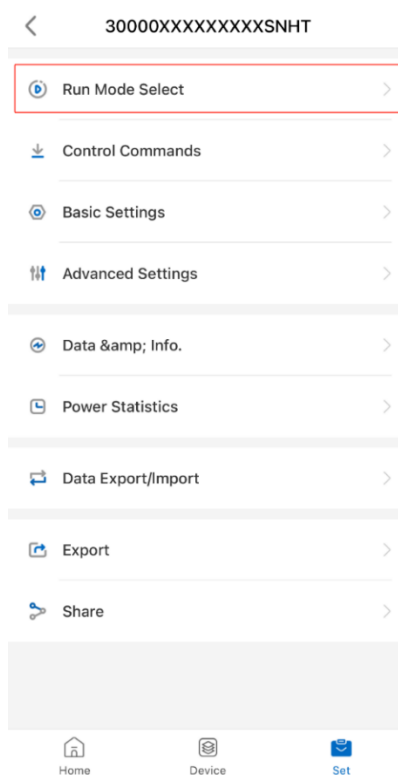

Figure 9-11 Run mode select

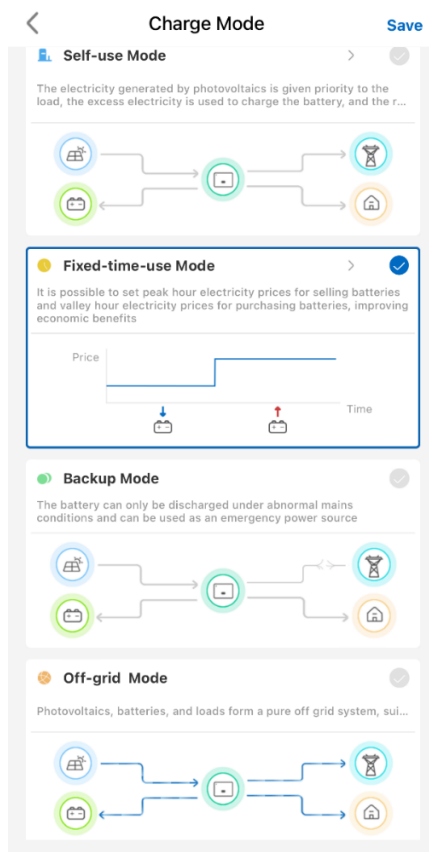

Figure 9-12 Fixed-time-use Mode

Date/time setting

There are three settings of timed charging and timed discharging.

Time: If the regular charging and discharging is not used, all periods should be set to 00:00 with the start time and end times controlled between 00:00 and 23:59, where the end time must be later than the start time, and the time cannot cover a day. When setting, all time periods must not overlap, otherwise the setting will not be successful.

Power: The power for forced charging of the battery.

Among them, the charging and discharging power of the battery changes with the change of SOC, and the charging power is the minimum value among the PV, the rated power of the model, and the charging and discharging limit of the battery.



Note

- The actual charge power is affected by the PV, the rated power based on the model, the battery charge, and discharge limit value and whether the battery is allowed to be charged the battery from the grid.

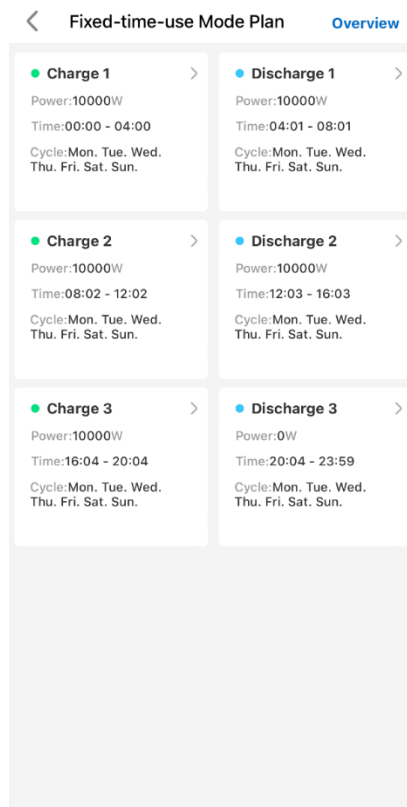

Figure 9-13 Date/time setting

Week setting

Week function: Set which day of the week the battery is charged or discharged.

If the current SOC is greater than the minimum on-grid SOC, it can be charged and discharged normally; the battery will stop discharging until the current SOC is less than or equal to the minimum on-grid SOC.

If the current SOC is less than 9%, the battery is forced to charge until the SOC reaches 14%.

Whether or not forced charging will be applied to the battery during actual use is also controlled by the command of the battery (if the battery requests forced charging, it will give priority to the forced charging of the battery).

In the event of a battery fault, stop battery charging or discharging.

In the event of a grid power failure, the equipment can be automatically switched to the off-grid mode.

9.5.3 Backup mode

Overview

In this mode, we should pay more attention to the problem of phase unbalanced. Ac output power will be divided according to the loads connected with each phase. At the same time, the

power of each phase cannot exceed the maximum power of the single phase, such as the rated power of the inverter is 30kW, and the single-phase load power cannot exceed 10kW.

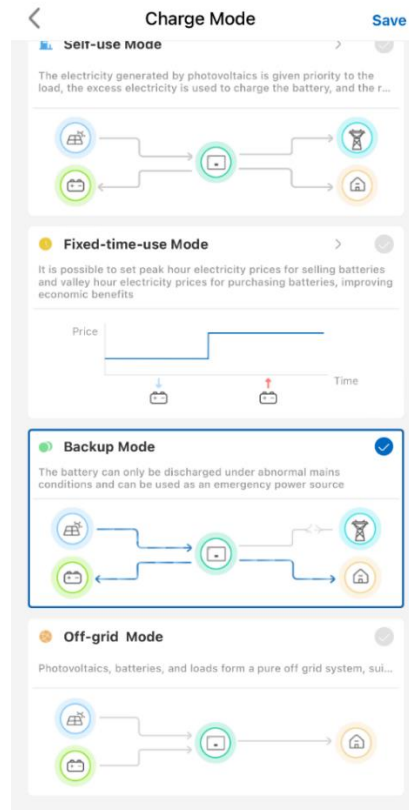

Figure 9-14 Backup mode

9.5.4 Off-grid mode (Active setting)

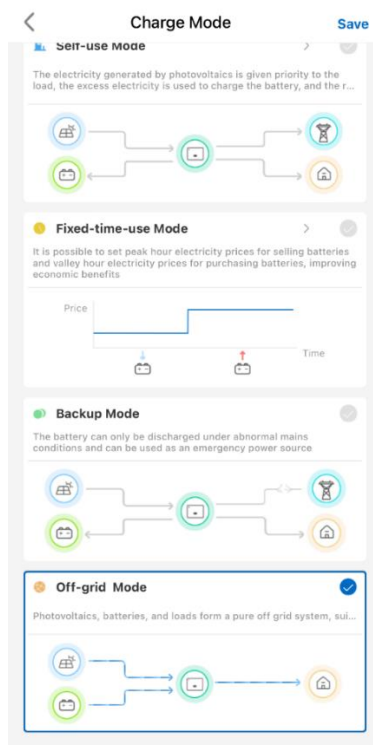

Figure 9-15 Off-grid mode



Caution

- When the inverter detects that there is no grid power, it enters the same operating mode as the forced off-grid mode, and system will use Off-grid minimum SOC as the battery protect limitation. The inverter will not automatically enter off-grid mode upon the first power-up.

9.6 Function and parameter settings

9.6.1 Remote control

When the remote control (advanced authority) (also called Passive Mode) is enabled, the inverter's own operating mode (Self-containment with the power generated, regular charge and discharge and back-up mode) will be deactivated. The negative is for charging, while the positive is for discharging. The data of remote-control enabling function and the remote-control power in the inverter are not stored, i.e., which means the inverter is deactivated after restarting. If you wish to continue using it, you must enable and set the power again.

This mode can only work in grid connected mode, and battery charging and does not control battery charging and discharging in off-grid mode (including no mains supply).

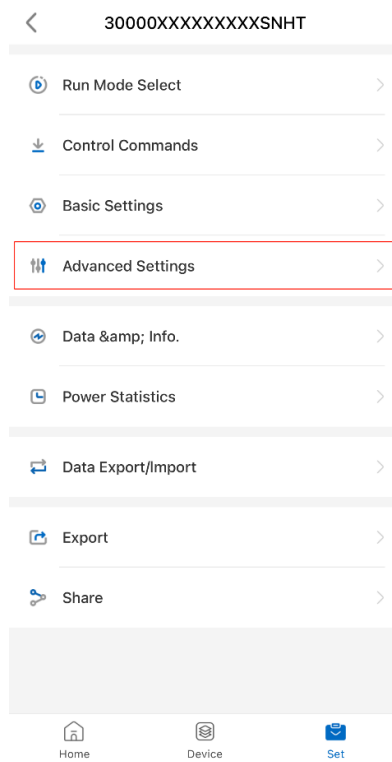

Figure 9-16 Advanced Settings

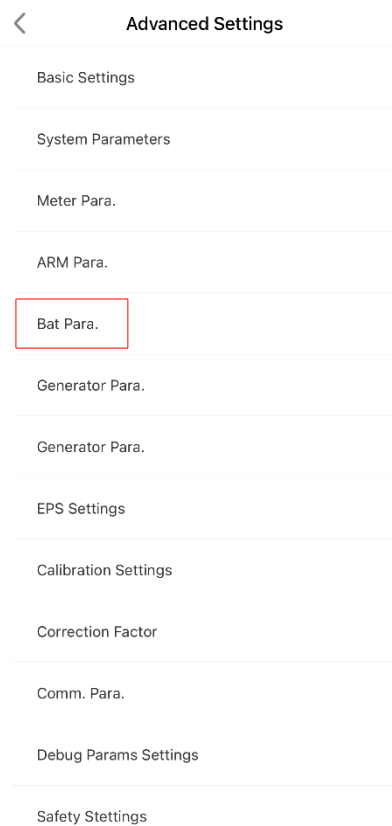

Figure 9-17 Bat para

The screenshot shows the 'Bat Para.' settings screen with the following parameters:

Parameter	Value
Battery Enable	Enable >
<small>Battery not connected and battery connected(Enable)</small>	
Enable_Passive Mode	Disable >
<small>Disable/Enable(Disable)</small>	
Charge/Discharge Mode_Passive Mode	0
<small>Positive for discharging negative for charging(0)</small>	
Battery ATS Testing Mode	Disable >
<small>Disable/Enable(Disable)</small>	
BMS Reset	NA >
<small>NA/Reset(NA)</small>	
Battery Wakeup	-- >
<small>Enable</small>	
Battery Type	Lithium >
<small>Lithium/Acid batteries(Lithium)</small>	
Number of Battery Packs	0
<small>0-65536(0)</small>	
Battery Manufacturer	PYLON >
<small>PYLON/Dyness/Weco/BYD/Aoboet(PYLON)</small>	
Battery Model	Gen-B >
<small>Unselected/Gen-A/Gen-B/Gen-C/Pylon/Dyness/Alpha/SiNeng1/SiNeng2/LG/BYD(Gen-B)</small>	
Mini.SOC Off-grid	10%

Figure 9-18 Bat para

9.6.2 Battery Settings

Function: energy store and power supply.

Battery Enable: The battery must be enabled during normal operation. If the battery communication is abnormal or the battery fails and stops after being enabled, the inverter will stop.

If you need to use the battery function, please enable the battery enable flag first.

Battery Disable: If the battery fails, if the inverter is still required to operate normally as a On-grid device, or if it is only required to be used as a On-grid inverter without a battery, the battery can be disabled, so that the energy storage inverter can be used as a On-grid inverter to supply power to the grid.

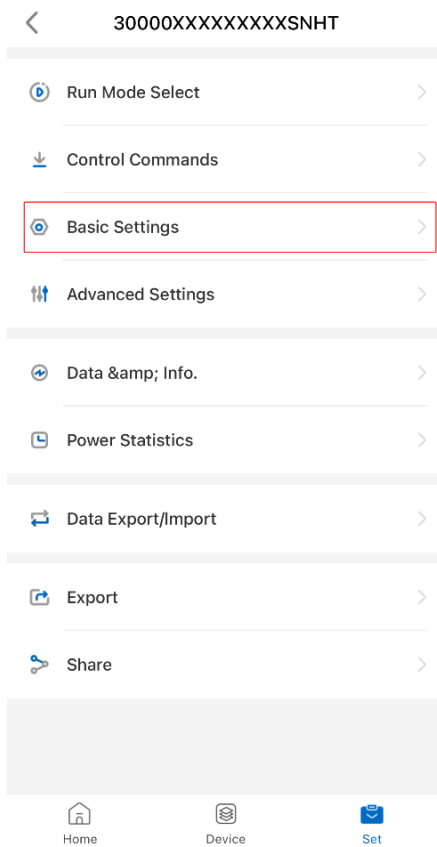

Figure 9-19 Basic Settings

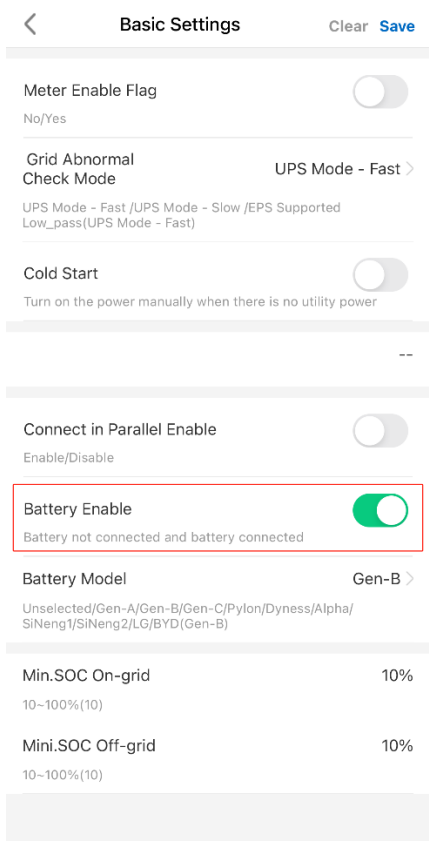

Figure 9-20 Battery Enable

Battery model: If the battery function is enabled, the battery model must be selected correctly, otherwise abnormal battery communication may occur and the inverter may not operate.

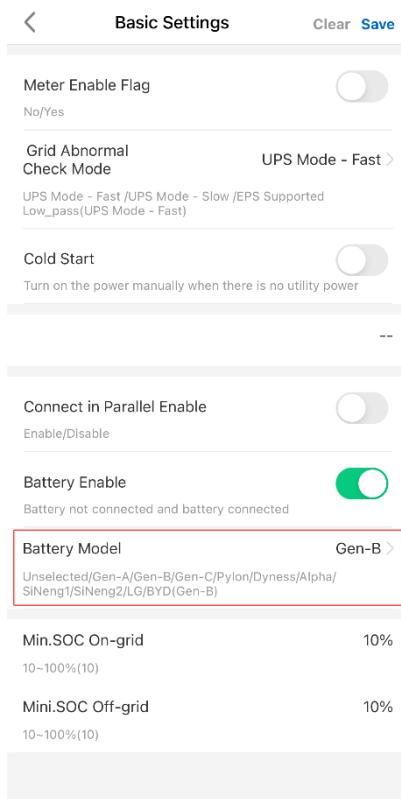

Figure 9-21 Battery Model 1

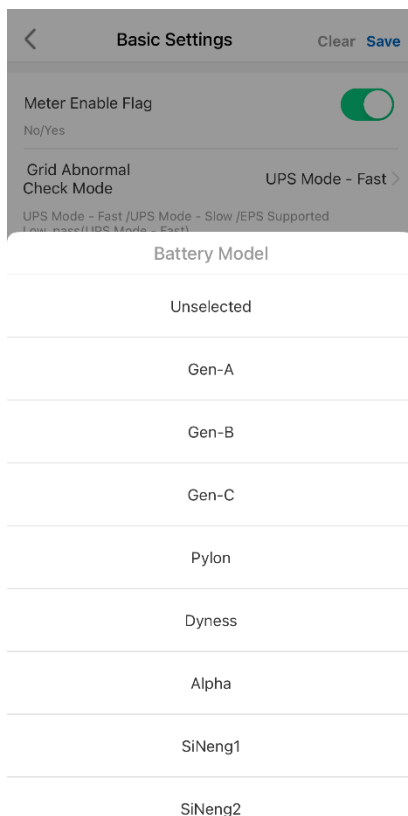

Figure 9-22 Battery Model 2

9.6.3 Smart meter

Function:

1. Used for export limit.
2. Adjust the inverter power according to the power of the energy meter under the self-use mode with the power generated and in the back-up mode.

Smart meter enabling: It can achieve the export limit function, adjust the inverter output power according to the power of the energy meter under the self-use mode with the power generated and back-up mode, and read real-time grid power, voltage, current and other parameters.

Smart meter disabling: Can not achieve export limit function, adjust the inverter output power according to the power of the ESP load under self-use mode with the power generated and back-up mode.

Smart meter model: Factory default setting.

Smart meter installation position: By default, the energy meter is installed on the grid side.

The factory default parameters of the energy meter communication are correct, please do not change them to avoid abnormal communication between the energy meter and the inverter.

Caution: If the energy meter and the inverter are connected to the three-phase grid, please ensure that the output of the energy meter and the inverter are in the same phase, otherwise the energy meter function will be disabled.

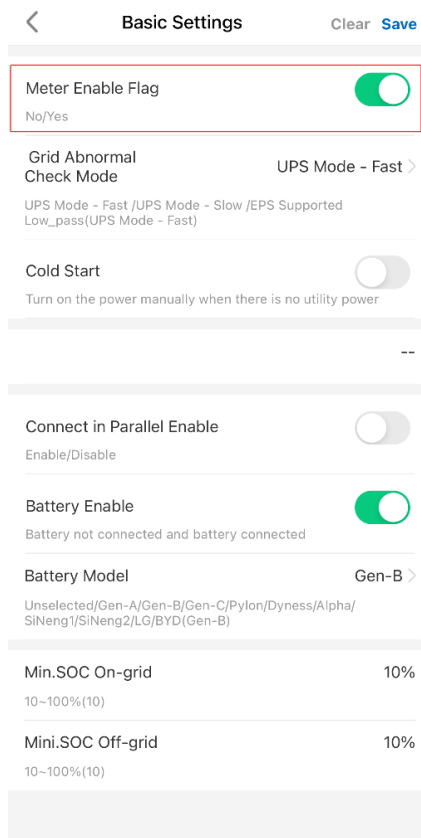

Figure 9-23 Meter Enable Flag

Three-Phase Adaptive Electricity Meter Instructions

Function: When the inverter voltage phase sequence is consistent with the grid phase sequence, this feature can automatically adjust the phase sequence and polarity of the meter when the meter phase sequence and polarity are incorrectly connected.

Note: If the battery cannot work, or the grid side does not support the three-phase four-wire connection method, the automatic phase adjustment function cannot be used. Please connect the wiring according to the correct method as shown in the meter wiring diagram.

Scenario Description:

The meter requires a three-phase four-wire connection, and the neutral wire must be correctly connected. When performing self-check of the meter, the inverter needs to ensure that it is connected to the battery and that the battery is functioning properly, and that it is connected to the meter and that the meter is working normally.

Operation Instructions:

- **Ensure Battery Enablement:** Make sure the battery is enabled, the correct battery model is selected, and the battery connections are accurate to guarantee the battery functions properly.
- **Ensure Meter Enablement:** Ensure that the electricity meter is enabled, the correct meter

model (DTSU666) is selected, and the meter connections are accurate to ensure the meter operates normally.

- The meter self-check needs to be carried out in the three-phase unbalanced mode. If the three-phase unbalanced mode is not enabled, the inverter will automatically enable the three-phase unbalanced mode (which will be automatically turned off after the test ends).

Note:

When the three-phase unbalance is enabled and the meter scheduling is enabled, the entire process of the meter self-check takes about 3 minutes.

When the three-phase unbalance is prohibited or the meter scheduling is prohibited, the entire process of the meter self-check takes about 5 minutes.

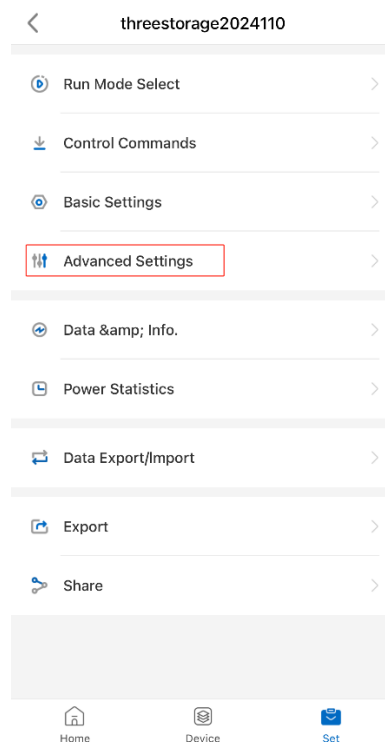

Figure 9-24 Advanced Settings 1

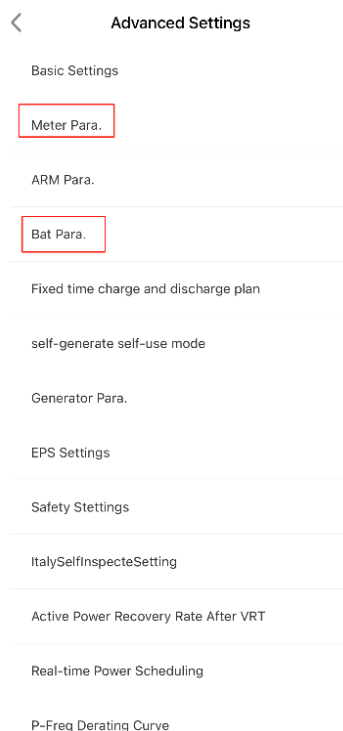

Figure 9-25 Advanced Settings 2

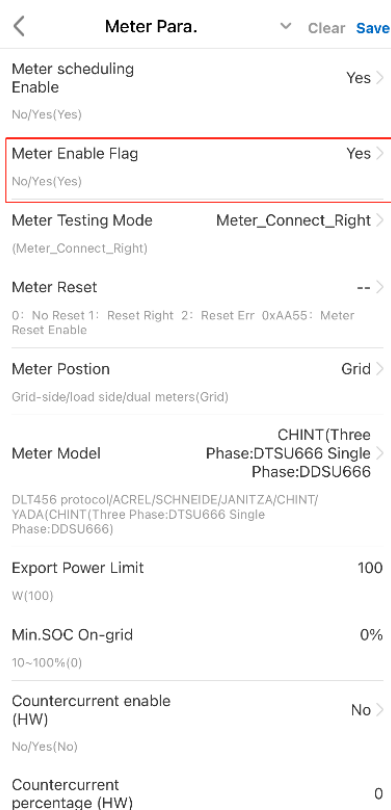

Figure 9-26 Meter Enable Flag

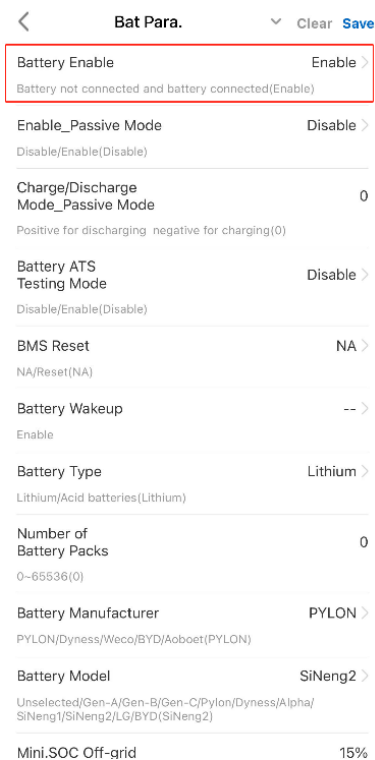

Figure 9-27 Battery Enable

- Meter Self-Check: Click on "Meter Self-Check Start" in the meter's test mode menu.

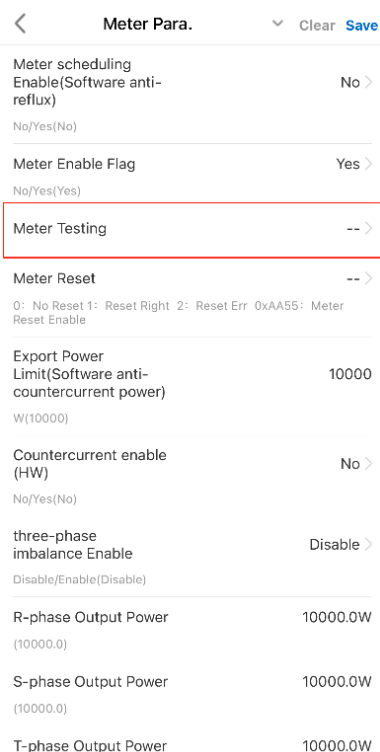

Figure 9-28 Meter Testing 1

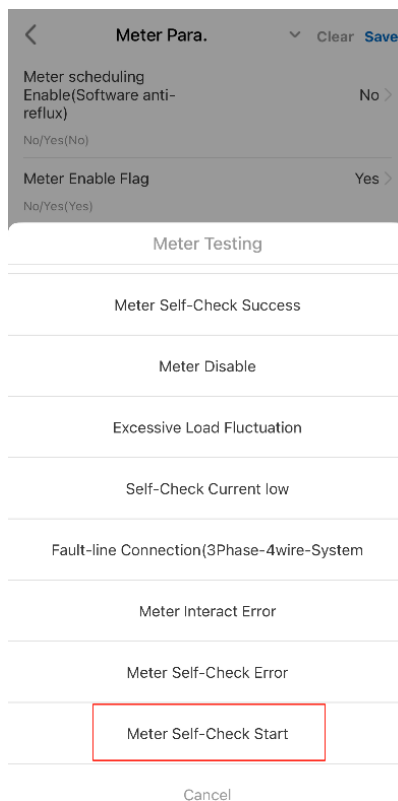

Figure 9-29 Meter Testing 2

- Self-Check Success Notification: If the self-check process is successful, the meter's test mode menu will display "Meter Self-Check Success".

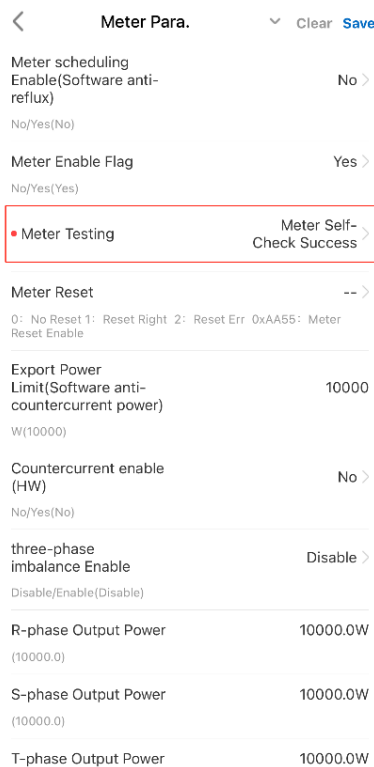
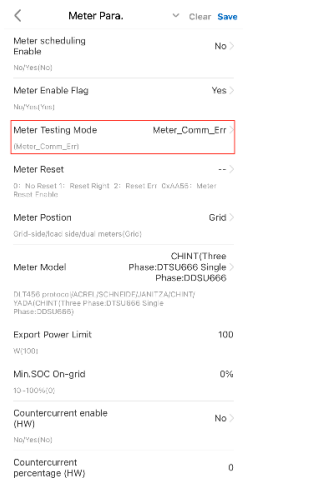
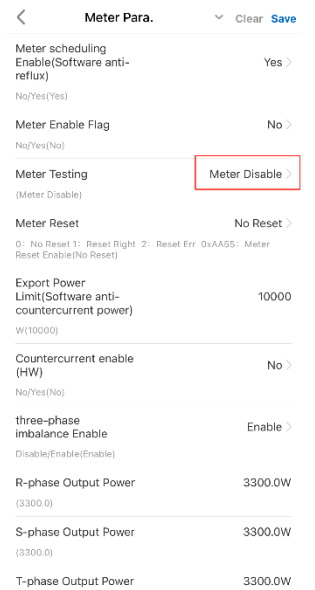

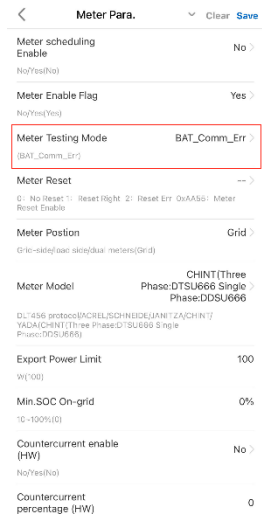

Figure 9-30 Self-Check Success Notification

- Self-Check Failure Notification: If the self-check of the meter is unsuccessful, the meter's

test mode menu will display the specific cause of the failure. For the causes of failure and their respective troubleshooting measures.

Table 9-1 Self-Check Failure Notification

Error description	APP display interface	Cause of failure	Error Handling
<p>Meter Communication Error</p>	 <p>The screenshot shows the 'Meter Para.' configuration screen. The 'Meter Testing Mode' is set to 'Meter_Comm_Err', which is highlighted with a red box. Other settings include 'Meter scheduling Enable' (No), 'Meter Enable Flag' (Yes), 'Meter Reset' (No Reset), 'Meter Position' (Grid), 'Meter Model' (CHNT), 'Export Power Limit' (100), 'Min.SOC On-grid' (0%), 'Countercurrent enable (HW)' (No), and 'Countercurrent percentage (HW)' (0).</p>	<p>Poor Communication Connection Mismatched Communication Address</p>	<p>Check Meter Wiring Connections. Check Communication Address [112].</p>
<p>Meter Disable</p>	 <p>The screenshot shows the 'Meter Para.' configuration screen. The 'Meter Testing' is set to 'Meter Disable', which is highlighted with a red box. Other settings include 'Meter scheduling Enable(Software anti-reflux)' (Yes), 'Meter Enable Flag' (No), 'Meter Reset' (No Reset), 'Export Power Limit(Software anti-countercurrent power)' (10000), 'Countercurrent enable (HW)' (No), 'three-phase imbalance Enable' (Enable), 'R-phase Output Power' (3300.0W), 'S-phase Output Power' (3300.0W), and 'T-phase Output Power' (3300.0W).</p>	<p>Meter Not Enabled</p>	<p>Check meter Enablement.</p>

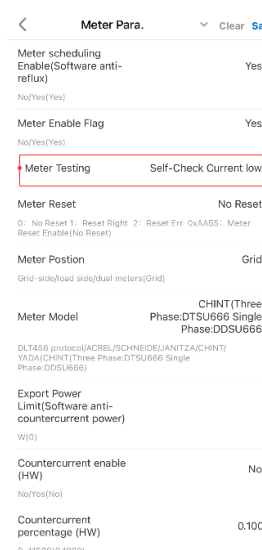
<p>BAT Communication Error</p>		<p>Battery Model Mismatch Battery Not Enabled Poor Communication Connection</p>	<p>Check Battery Model. Check Battery Enablement. Check Battery Wiring Connections.</p>
<p>Excessive Load Fluctuation</p>		<p>Home load fluctuations occurred during the self-check process of the electricity meter.</p>	<p>It is necessary to check for home load fluctuations during the self-check process, preferably with each phase load not exceeding 800W.</p>
<p>Self-Check Current low</p>		<p>When the power load on the grid side approaches 1KW every phase, it may result in the meter detecting a current lower than the required value.</p>	<p>It is suggested to increase or decrease the load. (The dynamic load range of every phase should be 0-0.63KW, and the static load range of every phase should be less than 0.63KW or greater than 1.17KW.)</p>

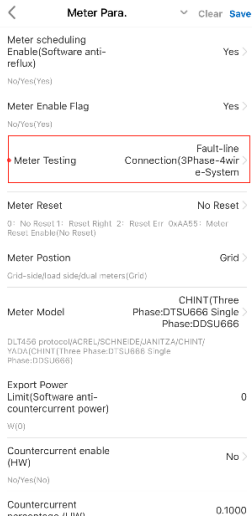
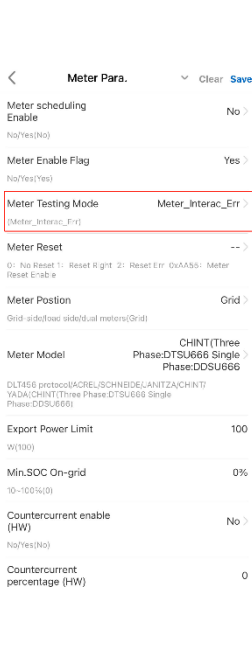
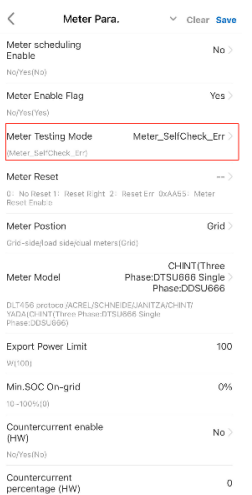
<p>Fault-line Connection (3Phase-4wire-System)</p>		<p>The self-check function of the meter is only applicable to three-phase four-wire meters.</p>	<p>Check the wiring of the meter and inverter to ensure it is a three-phase four-wire connection. Make sure the meter settings are configured for a three-phase four-wire system.</p>
<p>Meter Interact Error</p>		<p>The meter failed to exchange data with the inverter during the self-check process.</p>	<p>Check if the meter model has a self-check function. Check the connection of the meter's communication lines. Check if there is a significant difference between the meter's current, voltage, and the AC side data before the self-check starts.</p>
<p>Meter Self-Check Error</p>		<p>If the meter self-check fails, it will report a meter self-check error.</p>	<p>If the meter self-check fails, an error will be reported. For repeated failures, reset the meter to its original phase sequence and manually rewire according to the meter wiring diagram.</p>

Electricity Meter Reset

Function: This feature allows the restoration of the meter's phase sequence, CT (Current Transformer) phase sequence, and CT polarity to the unadjusted states.

Scenario Description: If the meter self-check fails to correct the phase and polarity, a reset to the default phase sequence is advised. Subsequently, align the Current Transformer (CT) sequence with the grid (L1, L2, L3, N), ensure the CT direction points towards the grid, and verify the correct voltage phase sequence as per the meter's wiring diagram.

Operation Instructions:

- Select the "Meter Reset" option in the electricity meter parameter list.
- Choose to enable the reset completed.

This process will revert the meter to its default settings, allowing you to start the wiring and configuration process a new, ensuring that all connections are made correctly according to the specifications.

Parameter	Value
Meter scheduling Enable(Software anti-reflux)	Yes >
<small>No/Yes(Yes)</small>	
Meter Enable Flag	Yes >
<small>No/Yes(Yes)</small>	
Meter Testing	-- >
Meter Reset	No Reset >
<small>0: No Reset 1: Reset Right 2: Reset Err 0xAA55: Meter Reset Enable(No Reset)</small>	
Export Power Limit(Software anti-countercurrent power)	1000
<small>W(1000)</small>	
Countercurrent enable (HW)	No >
<small>No/Yes(No)</small>	
three-phase imbalance Enable	Enable >
<small>Disable/Enable(Enable)</small>	
R-phase Output Power	3300.0W
<small>(3300.0)</small>	
S-phase Output Power	3300.0W
<small>(3300.0)</small>	
T-phase Output Power	3300.0W
<small>(3300.0)</small>	

Figure 9-31 Meter Reset 1

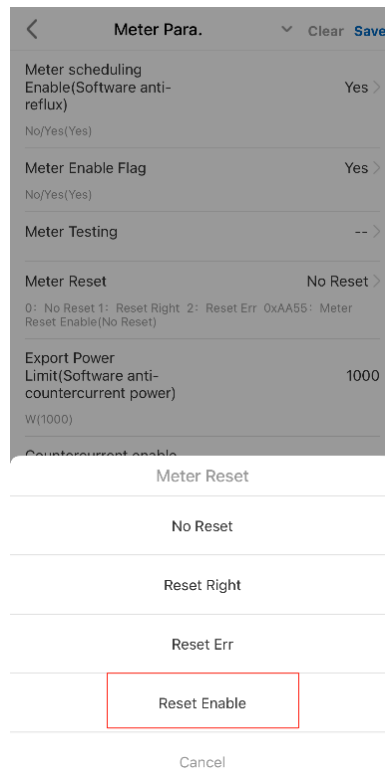

Figure 9-32 Meter Reset 2

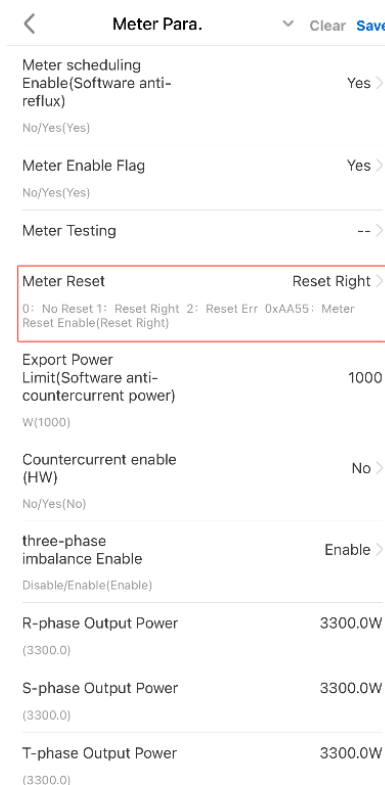

Figure 9-33 Meter Reset 3

9.6.4 On-grid minimum SOC

Function: In on-grid mode, the lowest SOC of the battery will all use this SOC.

In self-use mode with respect to the power generated, the battery will no longer be discharged when its real-time state of charge is less than this value.

In regular charge/discharge mode, when the real-time SOC of the battery is less than this value, it will no longer be discharged.

In standby mode, the battery is charged when the real-time charge state of the battery is less than this value, and the battery is not discharged when it is greater than this value.

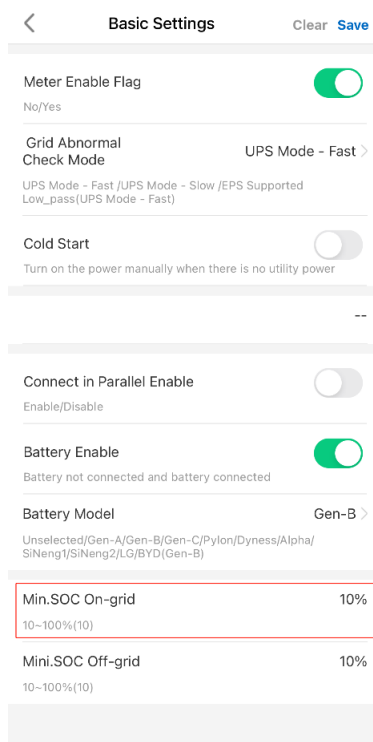

Figure 9-34 Min SOC On-grid

9.6.5 Off-grid minimum SOC

Function: The minimum SOC of the battery set in the off-grid mode or other mode without On-grid-in conditions, system will all use this SOC limitation parameters, with the range set as 10%~100%.

In both cases, when the battery SOC is greater than this value, it can be discharged, and when it is lower than this value, the battery can be charged according to the PV situation.

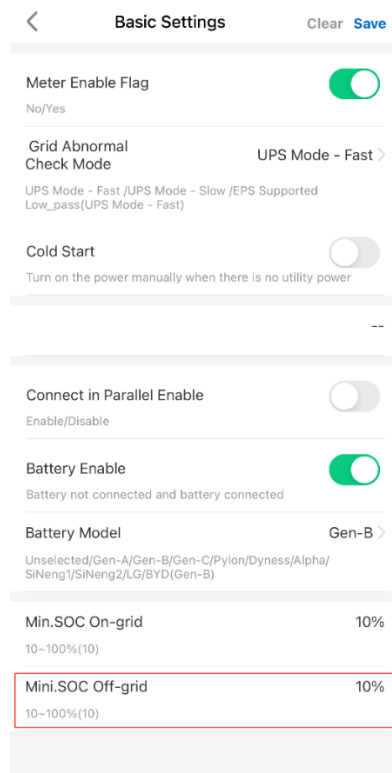

Figure 9-35 Mini SOC Off-grid

9.6.6 Low Battery SOC Protection

During the actual operation of the system, the battery may discharge to a state of low SOC. Prolonged or repeated charging and discharging of the battery will affect its BMS system, cause resource waste, and even endanger system safety. Our device is equipped with this function to protect the battery and ensure the safe and stable operation of the system.

When the battery is in a continuous discharge state, the system will protect the battery for the first time according to the "minimum SOC for On-grid" set by the user, and stop continuing to discharge;

When the battery is worn down for a long time, the SOC will further decrease. When the battery BMS "forced charging" command is triggered, the system will charge the battery under conditional charging situations until the "forced charging" command of the battery BMS disappears (there may be differences in the SOC values of different battery BMS in forced-charging and stopping-forced-charging. The system will automatically recognize them without any user action);

When the battery BMS "forced charging" command is triggered, in order to prevent the battery from still discharging at low battery level and repeatedly charging / discharging in a short period of time, the system will protect the battery from discharging for a certain period of time. The more times the BMS "forced charging" command is triggered, the longer the time delay will be;

When battery BMS "forced charging" command triggered 3 or more times, the system will no

longer allow the battery to discharge until the battery meets the charging conditions. After the battery BMS triggers the "forced charging" command and disappears, when charging reaches the SOC+3% hysteresis point, the battery charging or discharging will no longer be restricted by this function protection.

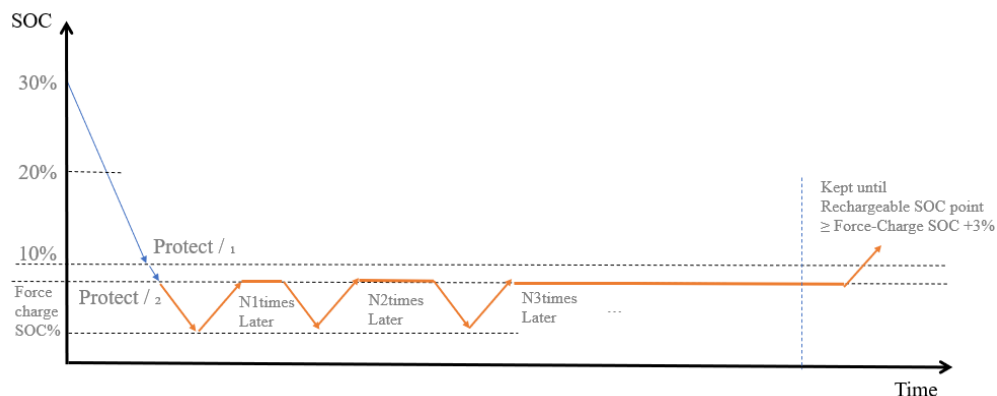

Figure 9-36 Low Battery SOC Protection

9.6.7 Forced charging

This occurs mainly when the battery power is low. To prevent the battery from being damaged due to the lack of battery power, there are two main situations:

1. When the battery SOC is below 9%, it is charged to 14% by the forced charging.
2. The battery will request a forced charge until the sign for forced charge request symbol disappears. The duration of the forced charge is different for each battery, if it is still less than 9%, it will continue to be charged to 14%.

9.6.8 Automatic forced SOC calibration

During prolonged operation, the battery may not consistently meet the SOC calibration conditions, which can lead to inaccuracies in SOC readings. To assist with SOC calibration for the battery, the inverter system will, after running for a certain period (which may vary depending on the battery type), charge the battery to 100% capacity at full power when the system has charging conditions and the battery is in a charging state. This process helps the Battery Management System (BMS) to complete a calibration of the battery's charge levels.

9.6.9 Three-phase Imbalance

Function: This function can separately control the power of each phase of the inverter sent to the grid.

The three-phase imbalance function will be activated when the inverter is connected to the battery, communicates normally with the electricity meter, and both the smart meter dispatch and

three-phase imbalance are enabled.

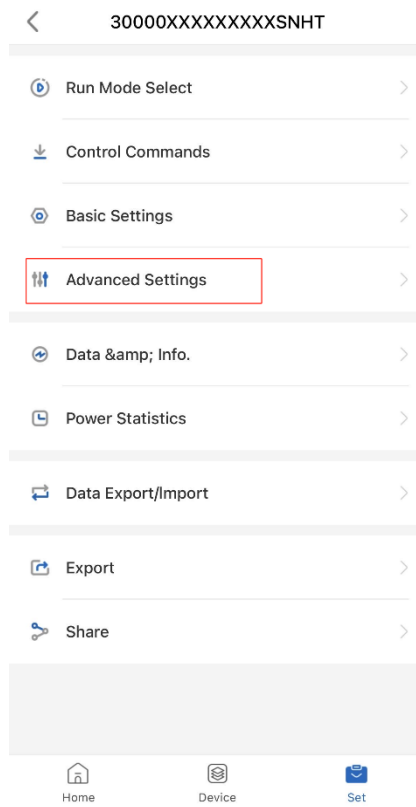

Figure 9-37 Advanced Settings 1

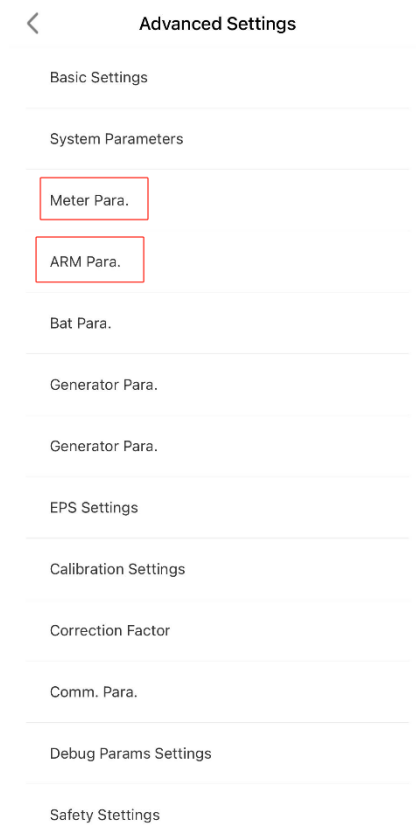

Figure 9-38 Advanced Settings 2

< Meter Para. Clear Save

Meter scheduling Enable	No >
<small>No/Yes(No)</small>	
Meter Enable Flag	Yes >
<small>No/Yes(Yes)</small>	
Meter Testing Mode	-- >
Meter Postion	Grid >
<small>Grid-side/load side/dual meters(Grid)</small>	
Meter Model	CHINT(Three Phase:DTSU666 Single Phase:DDSU666 >
<small>DLT456 protocol/ACREL/SCHNEIDER/JANITZA/CHINT/YADA(CHINT(Three Phase:DTSU666 Single Phase:DDSU666)</small>	
Export Power Limit	100
<small>W(100)</small>	
Min.SOC On-grid	10%
<small>10~100%(10)</small>	
Countercurrent enable (HW)	No >
<small>No/Yes(No)</small>	
Countercurrent percentage (HW)	0
<small>0~11500(0)</small>	

Figure 9-39 Meter Para.

< ARM Para. Clear Save

ARM Para.Reset	No >
<small>No/Yes(No)</small>	
ARM EX-chip memory reset	No >
<small>No/Yes(No)</small>	
Single energy storage aging mode	-- >
three-phase imbalance Enable	Disable >
<small>Disable/Enable(Disable)</small>	
R-phase Output Power	3000.0W
<small>(3000.0)</small>	
S-phase Output Power	3000.0W
<small>(3000.0)</small>	
T-phase Output Power	3000.0W
<small>(3000.0)</small>	
ARM buzzer enable	No >
<small>No/Yes(No)</small>	

Figure 9-40 Three-phase imbalance Enable

In the three-phase imbalance export limit function, the power limits according to the meter and the power output percentage limits for the inverter are introduced respectively.

- The power sent to the grid by any individual phase of the inverter can be limited by configuring the output power values for the R/S/T phases.

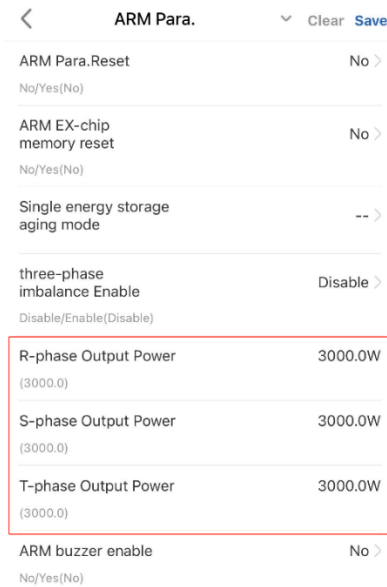

Parameter	Value
ARM Para.Reset	No >
ARM EX-chip memory reset	No >
Single energy storage aging mode	-- >
three-phase imbalance Enable	Disable >
R-phase Output Power	3000.0W
S-phase Output Power	3000.0W
T-phase Output Power	3000.0W
ARM buzzer enable	No >

Figure 9-41 ARM Para.

- R/S/T Phase Active Power Percentage Limitation.

By setting the active power percentages for the R/S/T phases, the power output of any individual phase of the inverter can be restricted (note that the active power percentages for the R/S/T phases are not saved in real-time; they will revert to the initial value of 115% upon re-energization).

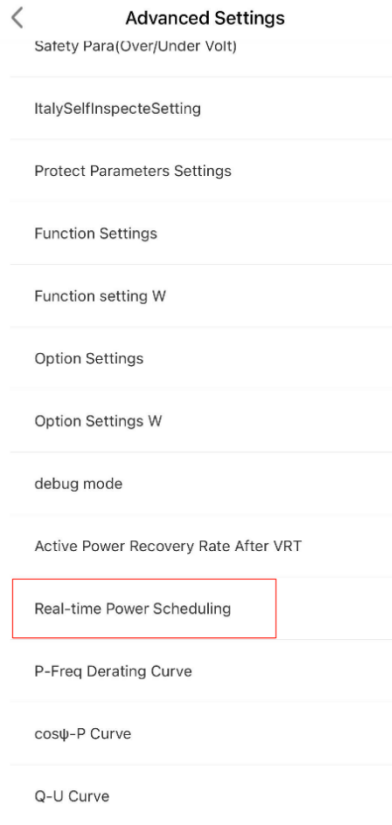

Figure 9-42 Real-time Power Scheduling 1

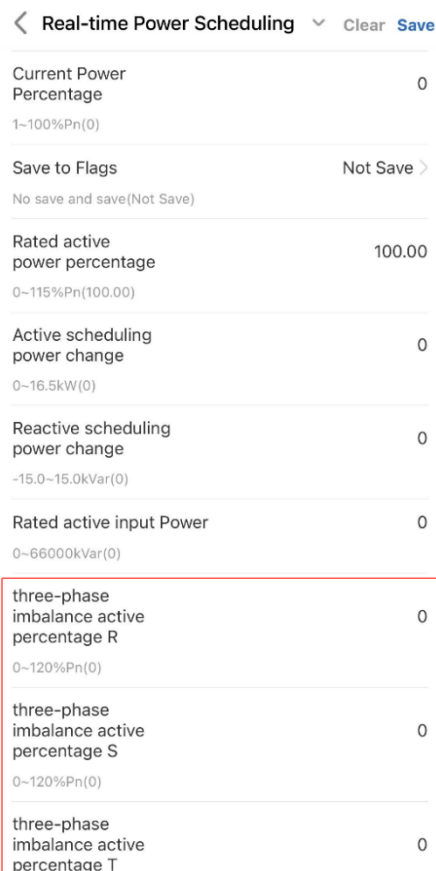

Figure 9-43 Real-time Power Scheduling 2

Note: When setting both the R/S/T phase output power values and the R/S/T phase active power percentages, the inverter will limit the power output based on the lower of the two values.

9.6.10 Export limit

Function: This function can control the power sent by the inverter to the grid.

The export limit function will be activated when the inverter is connected to the battery and the communication with the energy meter is correct.

In this introduction to the export limit function, software export limit function and hardware export limit function will be introduced separately. The settings also need to be set separately as export limit (software) / Export limit (hardware). When the safety regulations and standards in different countries are inconsistent, the system will automatically execute software, hardware, or software/hardware export limit functions that comply local safety regulations with user settings.

- Soft Limit, export limit (software)

It is necessary to activate the export limit function (also called Soft limit) and set the power sales limit, which controls the value of the power output to the grid.

- Hard Limit, export limit (hardware)
- Soft & Hard Limit, export limit (software and hardware)

When both export limit (software) and export limit (hardware) functions are turned on, the system will first use software export limit scheduling. If the software export limit adjustment still cannot achieve the purpose of preventing backflow, hardware export limit will be enabled.

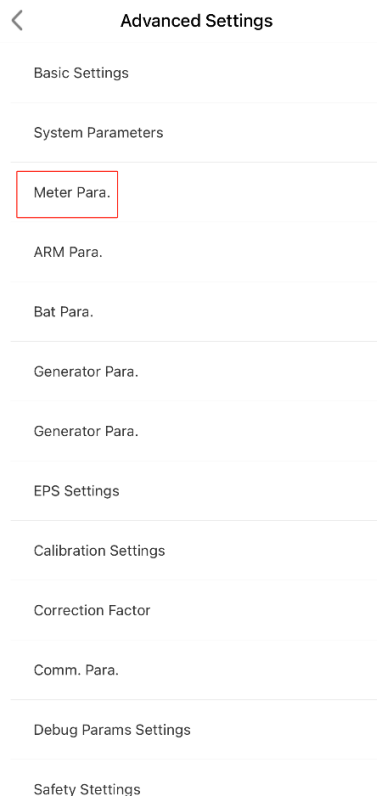

Figure 9-44 Advanced Settings

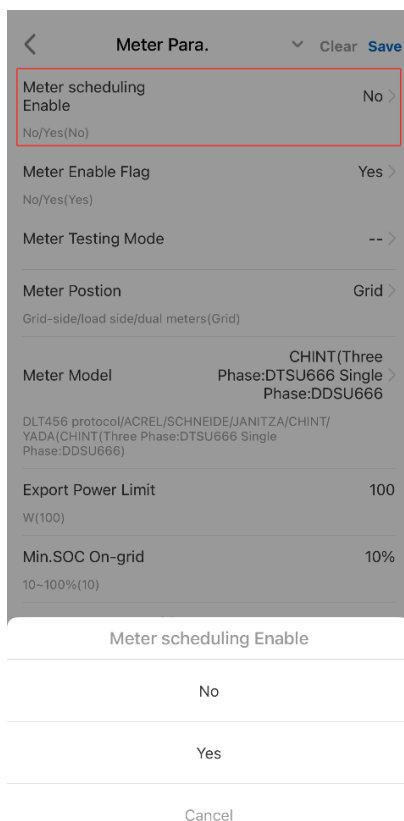

Figure 9-45 Meter scheduling Enable

9.6.11 DRM function

Function: This function can control the power taken from the grid and the power sent to the grid in real time.

DRM activation: Once enabled, the DRM function specified in the Australian safety regulations can be realized, and must work in conjunction with the DRM device to work. If DRM is enabled, but the inverter does not detect the DRM device, the inverter will consider that the DRM function to be abnormal, and the power harvesting and power generation are no longer be controlled by the DRM device.

It can send 100% power to the grid, and also take power with 100% power from the grid to charge the battery.

If this function is enabled, and the DRMs tool is also connected, but the detected state is invalid (multiple states exist at the same time), it can also send power to the mains at 100% power and take power from the grid with 100% power to charge the battery. For other states, see the description of DRMs.

DRM deactivation: Power consumption and power generation power are no longer controlled by DRM devices.

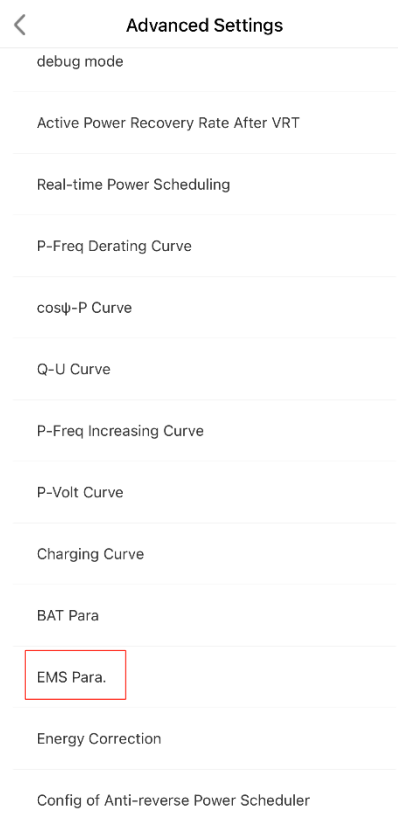

Figure 9-46 EMS Para.

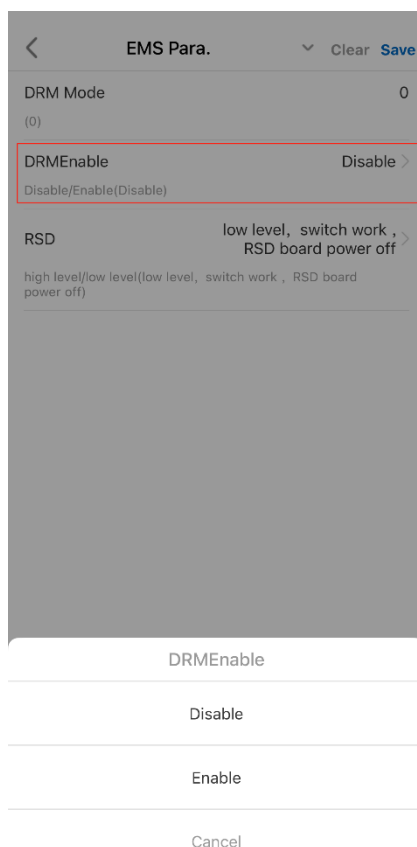

Figure 9-47 DRM Enable

9.6.12 IPS Self Inspect (For Italy CEI0-21 Grid Only)

Function: The Italy CEI0-21 grid code requires an IPS check for the SN5.0/6.0/8.0/10/10-X/12/15HT. During the self-inspect, the inverter checks the protection threshold and protection time of the maximum voltage over 10 min (59.S1), maximum overvoltage (59.S2), minimum undervoltage (27.S1), minimum undervoltage (27.S2), maximum over frequency (81.S1), maximum over frequency (81.S2), minimum underfrequency (81.S), and minimum underfrequency (81.S2).

Procedure: On the home screen, Advanced Settings > ITA > IPS Self Inspect > Italy IPS setting > Start > Tap Start to start an IPS test.

After the IPS test is complete, IPS State is displayed as Check completed.

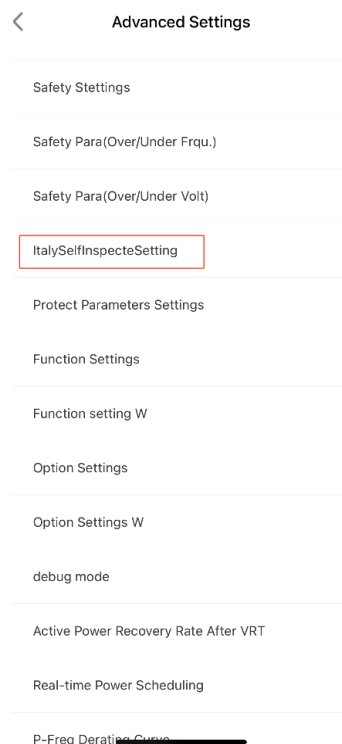

Figure 9-48 Advanced Settings 1

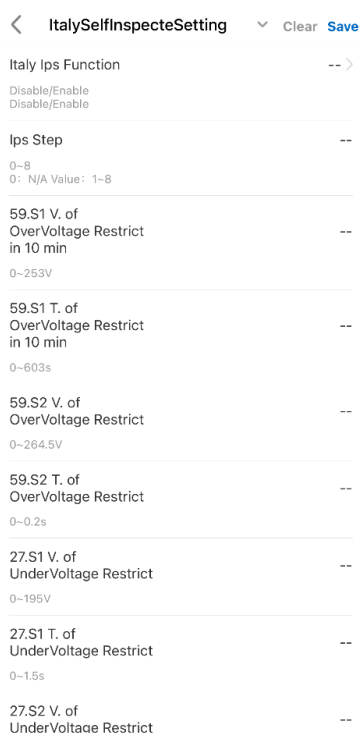

Figure 9-49 Advanced Settings 2

IPS Test Type	Description
Maximum voltage over 10 min (59.S1)	The default maximum voltage over 10 min protection threshold is 253 V (1.10 Vn), and the default protection time threshold is 3s.

Maximum overvoltage (59.S2)	The default overvoltage protection threshold is 264.5 V (1.15 Vn), and the default protection time threshold is 0.2s.
Minimum undervoltage (27.S1)	The default undervoltage protection threshold is 195.5 V (0.85 Vn), and the default protection time threshold is 1.5s.
Minimum undervoltage (27.S2)	The default undervoltage protection threshold is 34.5 V (0.15 Vn), and the default protection time threshold is 0.2s.
Maximum overfrequency (81.S1)	The default overfrequency protection threshold is 50.2 Hz, and the default protection time threshold is 0.1s.
Maximum overfrequency (81.S2)	The default overfrequency protection threshold is 51.5 Hz, and the default protection time threshold is 0.1s.
Minimum underfrequency (81.S1)	The default underfrequency protection threshold is 49.8 Hz, and the default protection time threshold is 0.1s.
Minimum underfrequency (81.S2)	The default underfrequency protection threshold is 47.5 Hz, and the default protection time threshold is 0.1s.

Chapter 10 List of Alarms



Warning

- The energy storage converter provides the power-on intelligent diagnosis function and automatically monitors the status of various internal components. When the energy storage converter prompts for critical faults, unable to power on, or maintenance information of other internal components, please contact Sineng customer service personnel.

This chapter describes common fault alarms and parameter thresholds of the energy storage converter.

Table 10-1 List of faults

Alarm ID	Alarm	Description
1	Grid Volt Abnormal	<ol style="list-style-type: none"> 1. Check that the AC output side voltage of the inverter meets the grid requirements. 2. Check that the phase sequence of the AC line is connected correctly and that the wiring sequence of the N line and PE is correct and fixed. If not fixed, please connect the Sineng customer service center.
4	Grid Freq abnormal	<ol style="list-style-type: none"> 1. Check that the AC output frequency of the inverter meets the grid standards. 2. Check that the phase sequence of the AC is connected correctly and that the wiring sequence of the N line and PE is correct and fixed. 3. Check the frequency of the fault. If it occurs occasionally, it may be caused by the instantaneous change in the mains frequency and no action is required. If not fixed, please connect the Sineng customer service center.
5	No Grid Volt	<p>The inverter will resume operation when the grid returns to normal. Otherwise:</p> <ol style="list-style-type: none"> 1. Check whether the AC switch of the inverter is on. 2. Confirm that the phase sequence of the AC line is connected correctly and that the wiring sequence of the N line and PE is correct.
6	Grid Sequence	<ol style="list-style-type: none"> 1. Check that the phase sequence of the AC line is correctly

Alarm ID	Alarm	Description
	Reverse	connected. 2. If phase sequence detection is not required, enable the phase sequence adaptive function. If not fixed, please connect the Sineng customer service center.
7	GFCI Fault	Wait for the inverter until it returns to normal. Otherwise: A humid environment or poor lighting will cause this fault, and the inverter will return to operation when the environment improves; If the environment is normal, check whether the insulation of the DC and AC cables is normal; 3. Confirm that the cause is not one of the above and if the fault still exists, please contact the Sineng customer service center.
8	ISO Fault	Wait for the inverter to return to normal. Otherwise: 1. Check the impedance of the strings and the DC cables to the earth. If there is a short circuit or if the cable insulation is damaged, please take corrective action; 2. If the cable is normal and the fault occurs on a rainy day (or in the morning with dew), check when the weather improves; 3. If it is confirmed that the cause is not one of the above, but the fault still exists, please contact the Sineng customer service center.
9	DCI Fault	Check that the phase sequence of the AC line is correct, and that the wiring sequence of the N line and PE is correct. If not fixed, please connect the Sineng customer service center.
10	NPE Volt Fault	Measure if the voltage of the grid N-line to earth is higher than 30V. If not fixed, please connect the Sineng customer service center.
12	EPS Overload	The output load power is too high. Check whether the power of the output load is greater than the rated power of the inverter. If so, it must be disconnected. Use a load that is less than or equal to the rated power of the inverter and restart the inverter. If the fault information remains, contact the Sineng customer service center.

Alarm ID	Alarm	Description
13	AC Port Reversed	Reverse the wiring of the EPS terminal and the mains terminal. Reverse the wiring terminal of EPS and that of the utility power, then restart the inverter, if the fault information remains, please contact the Sineng customer service center.
14	Load NPE Fault	Measure if the voltage of the Load N-line to earth is higher than 30V. If not fixed, please connect the Sineng customer service center.
16	Neutral Disconnected (EPS_Grid)	Eps_N is not connected to grid N Disconnect the AC side switch, the DC side switch, and the battery switch. Check whether the Eps_N is connected to the N wire of the mains. If not, connect the Eps_N to the N wire of the mains, and the machine will operate normally. If the fault information remains, please contact the Sineng customer service center.
21	Device Fault	1. Wait for the inverter returns to normal. 2. Turn off the AC & DC switch, wait for 15 minutes and then restart the inverter. If not fixed, please connect the Sineng customer service center.
23	Temp High	1. Ensure that the installation environment and space of the inverter meet the heat dissipation requirements. 2. Check that the fan is not blocked by foreign objects and confirm that the fan can operate normally. 3. Check that the ambient temperature of the inverter is not too high. If not fixed, please connect the Sineng customer service center.
24	M-DSP Version Fault	DSP version issue, please contact the Sineng customer service center.
25	Communication Error (DSP-ARM)	1. Wait for the inverter to return to normal. 2. If faults occur frequently please contact the Sineng customer service center.
26	Communication Error (Master-Slave)	Wait for the inverter to return to normal. 2. If failures occur frequently please get in touch with the after-sales service center.

Alarm ID	Alarm	Description
28	Logical Interface Enabled	<ol style="list-style-type: none"> Under this mode, the inverter can be shut down by the logical interface. If failures occur frequently without logical interface being enabled, please get in touch with the after-sales service center.
29	Device Model Mismatch	Please connect the Sineng customer service center.
33	BUS Volt High	<ol style="list-style-type: none"> Restart the inverter and check that it is operating normally. Check that the PV string voltage meets the maximum input voltage requirements of the inverter. If not fixed, please connect the Sineng customer service center.
39	AFCI Fault	<ol style="list-style-type: none"> Check the DC side for damaged cables, loose terminals, poor contact, and scorch marks on components; if so, replace any abnormal cables, terminals, or other components. Clear the error message. If not fixed, please connect the Sineng customer service center.
40	PV Volt High	<ol style="list-style-type: none"> Check that the PV string input voltage matches the inverter display. Check that the PV string voltage meets the maximum input voltage requirements of the inverter. If not fixed, please connect the Sineng customer service center.
41	PV reverse	<ol style="list-style-type: none"> Check whether the string corresponding to the alarm is reserved. If so, it is recommended to turn off the DC switch and reserve the string polarity when the solar irradiance decreases and the string current drops below 0.5A; Confirm that the cause is not one of the above and the fault still exists, please contact the Sineng customer service center.
42	PV More Panels	<ol style="list-style-type: none"> Check that the PV string input voltage matches the inverter display. Check that the PV string voltage meets the maximum input voltage requirements of the inverter. If not fixed, please connect the Sineng customer service center.
44	Series Temperature High	<ol style="list-style-type: none"> Confirm that the installation environment and the space around the inverter meet the heat dissipation requirements. Check that the fan is not blocked by other objects and confirm that the fan can operate normally.

Alarm ID	Alarm	Description
		<p>3. Check that the ambient temperature of the inverter is not too high.</p> <p>4. Once the fault has been cleared manually, restart the inverter; if the fault occurs frequently, please contact the Sineng customer service center.</p>
48	Battery Volt Out Range	<p>Check the battery voltage.</p> <p>If the battery voltage exceeds the allowable range, the inverter will operate normally when the voltage returns to normal. If the battery voltage is within the allowed range, and the fault information remains, please contact the Sineng customer service center.</p>
50	EPS Volt Out Range	Restart the inverter, if the fault information is still present, please contact the Sineng customer service center.
55	EPS over current	<p>The output load current is too high.</p> <p>Check whether the power of the output load is greater than the rated power of the inverter. If so, it must be disconnected. Use a load that is less than or equal to the rated power of the inverter and restart the inverter. If the fault information remains, contact the Sineng customer service center.</p>
65	Relay Fault	<p>1. Restart the inverter and check that it is operating normally.</p> <p>2. Check that the wiring of the inverter is correct (Neutral & PE).</p> <p>If this happens frequently, please contact the Sineng customer service center.</p>
79	Internal Fan Fault	If this happens frequently, please contact the Sineng customer service center.
80	External Fan Fault	If this happens frequently, please contact the Sineng customer service center.
201	AC Curr High	<p>The inverter monitors the external operating conditions in real time, and the inverter will resume normal operation after the fault disappears, no manual intervention is required.</p> <p>If this alarm occurs frequently, check that there is no short circuit in the external output circuit; if the problem cannot be solved, please contact the Sineng customer service center.</p>
202		The inverter monitors the internal operating conditions in real

Alarm ID	Alarm	Description
	AC Curr Hardware Protect	time, and resumes normal operation when the fault is cleared, without the need for manual intervention. If this alarm occurs frequently, check that there is no short circuit in the external output circuit; if the problem cannot be solved, please contact the Sineng customer service center.
203	HVRT	If it occurs accidentally, it may be caused by a short-term abnormality of the grid The inverter will resume normal operation when it detects that the grid has recovered, no manual intervention is required. If it occurs frequently, please check that the grid voltage is within the allowable range, If not fixed, please connect the Sineng customer service center.
204	LVRT	If it occurs accidentally, it may be caused by a short-term abnormality of the grid The inverter will resume normal operation when it detects that the grid has recovered, no manual intervention is required. If it occurs frequently, please check that the grid voltage is within the allowable range, If not fixed, please connect the Sineng customer service center.
205	PV-PE Volt High	Wait for the inverter to recover; If the inverter cannot be restored for a long time, disconnect the switch on the AC side switch and DC side switch, wait for 5 minutes, and then close the AC and DC switches in turn. Restart the inverter, if the fault information still exists, contact Sineng customer service center.
206	Island	If it occurs accidentally, it may be caused by a short-term abnormality of the grid The inverter will resume normal operation when it detects that the grid has recovered, no manual intervention is required. If it occurs frequently, please check that the grid frequency is within the acceptable range, If not fixed, please connect the Sineng customer service center.
207	DSP EEPROM fault	1. Restart the inverter and check that it is operating normally. 2. If this happens frequently, please contact the Sineng

Alarm ID	Alarm	Description
		customer service center.
208	RTC Fault	1. Restart the inverter and check that it is operating normally. 2. If this happens frequently, please contact the Sineng customer service center.
209	MCU_Register Fault	1. Restart the inverter and check that it is operating normally. 2. If this happens frequently, please contact the Sineng customer service center.
210	MCU_RAM Fault	1. Restart the inverter and check that it is operating normally. 2. If this happens frequently, please contact the Sineng customer service center.
214	Temp Low	Wait for the ambient temperature to return to the specified range, and then the inverter will start up automatically. If not fixed, please connect the Sineng customer service center.
219	MPPT overcurrent	Wait for the inverter to recover; If the inverter cannot be restored for a long time, disconnect the switch on the AC side switch and DC side switch, wait for 5 minutes and close the AC and DC switches in turn. Restart the inverter, if the fault information still exists, contact the Sineng customer service center.
220	MPPT overcurrent (hardware)	Restart the inverter, if the fault information is still present, please contact the Sineng customer service center.
221	MPPT Start Volt Out Range	Check the series configuration of the photovoltaic panels to ensure that the open-circuit voltage of each string is lower than the maximum operating voltage of the inverter. After the configuration is correct, the inverter will automatically start. If not fixed, please connect the Sineng customer service center.
223	Boost1 current limiting	The inverter monitors the internal operating conditions in real time, and resumes normal operation when the fault is cleared, without the need for manual intervention. If this alarm occurs frequently and the problem cannot be solved, please contact the Sineng customer service center.
224	Boost2 current limiting	The inverter monitors the internal operating conditions in real time, and resumes normal operation when the fault is cleared, without the need for manual intervention. If this alarm occurs

Alarm ID	Alarm	Description
		frequently and the problem cannot be solved, please contact the Sineng customer service center.
229	AC current limiting	The inverter monitors the internal operating conditions in real time, and resumes normal operation when the fault is cleared, without the need for manual intervention. If this alarm occurs frequently and the problem cannot be solved, please contact the Sineng customer service center.
230	Inverter PWM abnormality	The inverter monitors the internal operating conditions in real time, and resumes normal operation when the fault is cleared, without the need for manual intervention. If this alarm occurs frequently and the problem cannot be solved, please contact the Sineng customer service center.
241	BuckBoost Over-current (Hardware)	Restart the inverter and if the fault information is still present, please contact the Sineng customer service center.
245	BuckBoost over-current	Restart the inverter, if the fault information is still present, please contact the Sineng customer service center.
247	Balance Bridge Overcurrent(Hardware)	The output half wave load power is too high. Check whether the half wave load power of the output load is greater than the sixth rated power of the inverter. If so, it must be disconnected. Use a load that is less than or equal to the sixth rated power of the inverter of the inverter and restart the inverter. If the fault information remains, contact the Sineng customer service center.

Chapter 11 Product Maintenance

If the inverter runs in a harsh environment, such as a desert area, the corresponding maintenance cycle should be shortened. Especially, the internal and external cleaning, anti-corrosion and anti-rust work should be more frequent. The maintenance cycles provided in this section are reference values. The actual maintenance cycles should be reasonably determined based on the actual environmental conditions on site.



Warning

- Only professionals are allowed to maintain the inverter. Others cannot maintain it without authorization.
- In order to ensure the safety of maintenance personnel, it is prohibited to touch any live parts of the inverter when the inverter is running, and always check whether the ground point of the inverter is reliably connected.
- Unauthorized or non-permitted disassembly of the inverter may cause damage to the equipment. Such equipment damage is not covered by the product warranty.

11.1 Daily Inspection of Inverter

Table 11-1 Daily inspection items

Maintenance Item	Inspection Method
Appearance	Check for abnormal phenomena such as damage, deformation, corrosion, cracks, foreign objects, dust, water stains and other pollutants, and dangerous signs such as odor, smoke, and sparks.
Operating status	Check the operating status of the inverter. Check for abnormal sounds, vibrations, temperatures, etc., and for faults such as overload, overvoltage, undervoltage, overcurrent, and short circuit.
Electrical inspection	Check whether the input and output voltage, current, power, frequency, power factor and other inverter parameters are within the specified range, whether they are stable and reliable, and whether they have fluctuations, deviations, harmonics and other problems.
Heat dissipation	Check whether the ventilation and cooling system of the ventilator is blocked, clogged, or damaged, whether there is overheating, overcooling, and condensation, and whether the fan, radiator, filter and other components are damaged, aged, or falling off.

Maintenance Item	Inspection Method
Cable connection	Check whether the grounding, wiring, connection and other parts of the inverter are loose, broken, worn, and oxidized, and whether there are potential dangers such as poor contact, leakage, and arcing.

11.2 Periodic Inspection of Inverter

Table 11-2 Maintenance items (semi-annual inspection)

Sign	Maintenance Item	Inspection Method
1	Surrounding vegetation cleanup	There are no weeds or other vegetation around the inverter
2	Air inlet and outlet	The inlet and outlets need to be unobstructed, without any foreign body coverage or dust accumulation
3	Radiator	The radiator has no foreign body coverage or dust accumulation.
4	Fan	<ul style="list-style-type: none"> ● Check whether there is abnormal noise when the fan is running. ● Check whether the fan blades have cracks. ● Check whether the fan is blocked by foreign matter. ● Check whether derating protection is enabled for the fan.
5	Check the grounding reliability	<ul style="list-style-type: none"> ● All ground connections are reliable, no loose ● All ground cables are not damaged and oxidized ● Use a multimeter to detect whether the ground impedance at the ground screw of the inverter is $\leq 4\Omega$
6	Electrical inspection	<ul style="list-style-type: none"> ● All cable connections are reliable, no loose, no fall off. ● All wiring cables are not damaged, oxidized, and naked of core wires ● All wiring terminals are reliable, no loose, no break. ● All unused DC input terminals are sealed tightly and have no drop. ● All unused COM interfaces, waterproof caps of USB interfaces need to be locked. ● Tighten all cable locks.
7	Equipment inlet hole	All equipment entering holes need to be blocked completely without a large gap.

Appendix A System Specifications

Table A-1 PV Input

Item	SN20HT	SN25HT	SN29.9HT	SN30HT	SN33HT
Maximum DC power (W)	30000	37500	45000		
Maximum inverter voltage (V)	1000				
Rated voltage (V)	620				
Startup voltage (V)	180				
MPPT operating voltage range (V)	160-950				
Full load MPPT voltage range (V)	280-800	350-800			385-800
Number of MPPT tributaries	3				
MPPT structure	2/2/1		2/2/2		
Maximum input current of MPPT	32/32/20		40/32/32		
Maximum short-circuit current of MPPT	50/50/25		50/50/50		
Max.inverter backfeed current to the array (A _{dc})	0				

Table A-2 Battery side input/output

Item	SN20HT	SN25HT	SN29.9HT	SN30HT	SN33HT
Battery type	Lithium battery				
Battery interface	2				
Battery voltage level	High voltage				
Battery voltage range (V)	180-800				
Rated voltage of battery (V)	620				
Maximum charging and discharging power (W)	20000	25000	30000		33000
Maximum charging and discharging current (A)	50*2				
Communication mode	CAN				

Table A-3 On-grid

Item	SN20HT	SN25HT	SN29.9HT	SN30HT	SN33HT
Rated output power (W)	20000	25000	29900	30000	33000
Max. output power (W)	20000	27500	29000	33000	33000
Rated AC side voltage (Vac)	3/(N)/PE,220/380V;230/400V;240/415V				
Rated AC side frequency (Hz)	50/60				
Rated output current (A)	30.4A/220V 29.0A/230V 27.8A/240V	37.9A/220V 36.3A/230V 34.8A/240V	45.5A/220V 43.5A/230V 41.6 A/240V	45.5A/220V 43.5A/230V 41.7A/240V	50A/220V 47.9A/230V 45.9A/240V
Max. output current (A)	30.4A/220V 31.9A/230V 30.6A/240V	41.7A/220V 39.9A/230V 38.2A/240V	45.4A/220V 43.4A/230V 41.6A/240V	50A/220V 47.9A/230V 45.9A/240V	
Output current waveform distortion	<3%				
Output power factor	Adjustable range: -0.8 lagging ~+0.8 leading				
Inrush Current (peak and duration)	4.4A@18ms				
Conditional short-circuit current (Icc)	<10kA				

Table A-4 Off-grid

Item	SN20HT	SN25HT	SN29.9HT	SN30HT	SN33HT
Rated output power (W)	20000	25000	29900	30000	33000
Max. output power (W)	22000	27500	33000		
Max. Short-period Output power	24000<P≤ 30000,10s; 22000<P≤ 24000,60s	30000<P≤ 37500,10s; 27500<P≤ 30000,60s	36000<P≤42900,10s; 33000<P≤36000,60s		
Switching time (ms)	10				
Output rated voltage (Vac)	3/(N)/PE,220/380V;230/400V;240/415V				
Rated frequency (Hz)	50/60				

Rated output current (A)	30.4A/220V	37.9A/220V	45.5A/220V	50A/220V
	29.0A/230V	36.3A/230V	43.5A/230V	47.9A/230V
	27.8A/240V	34.8A/240V	41.7A/240V	45.9A/240V
Long term max. output current (A)	33.4A/220V	41.7A/220V	50A/220V	50A/220V
	31.9A/230V	39.9A/230V	47.9A/230V	47.9A/230V
	30.6A/240V	38.2A/240V	45.9A/240V	45.9A/240V

Table A-5 Efficiency

Item	SN20HT	SN25HT	SN29.9HT	SN30HT	SN33HT
Max. inverter efficiency	98.3%				
European efficiency	97.5%				
Battery max. charging efficiency By PV	98.5%				

Table A-6 Protection characteristics

Item	SN20HT	SN25HT	SN29.9HT	SN30HT	SN33HT
DC reverse polarity protection	Yes				
Leakage current protection	Yes				
Islanding protection	Yes				
Output current protection	Yes				
DC switch	Yes				
Insulation resistance detection	Yes				
AFCI	Yes				
AC and DC surge protection	II				
LPS	DC: II, AC: II				
RSD	Optional				

Table A-7 AC side input

Item	SN20HT	SN25HT	SN29.9HT	SN30HT	SN33HT
Maximum input power (W)	37500		42900		
Maximum input current (A)	56.9A/220V	56.9A/220V	65A/220V		
	54.4A/230V	54.4A/230V	62.2A/230V		
	52.1A/240V	52.1A/240V	59.6A/240V		

Rated input voltage (V)	3/(N)/PE,220/380V;230/400V;240/415
Rated input frequency (Hz)	50/60

Table A-8 Regular parameters

Item	SN20HT	SN25HT	SN29.9HT	SN30HT	SN33HT
Dimensions/ H×W×D (mm)	680*554*268				
Net Weight (kg)	41	41	42	42	42
Operating temperature (°C)	-25~60				
Storage temperature (°C)	-40~70				
Relative humidity	0~100%, no condensation				
Altitude	4000m (>3000m, the voltage is derate to 980V)				
Display and operation UI	LED, APP				
IP rating	IP66				
Cable entry method	Lower cable entry and lower cable exit				
Communication	CAN, RS485, WIFI				
Noise (dB)	≤60				
Cooling method	Smart air cooling				
Topology	Transformerless				
PV side wiring method	MC4				
Self-consumption at night	<25W				

Appendix B Electrical system wiring diagram

This diagram is an example for an application that neutral connects with the PE in a distribution box.
 For countries such as Australia, New Zealand, South Africa, etc., please follow local wiring regulations!

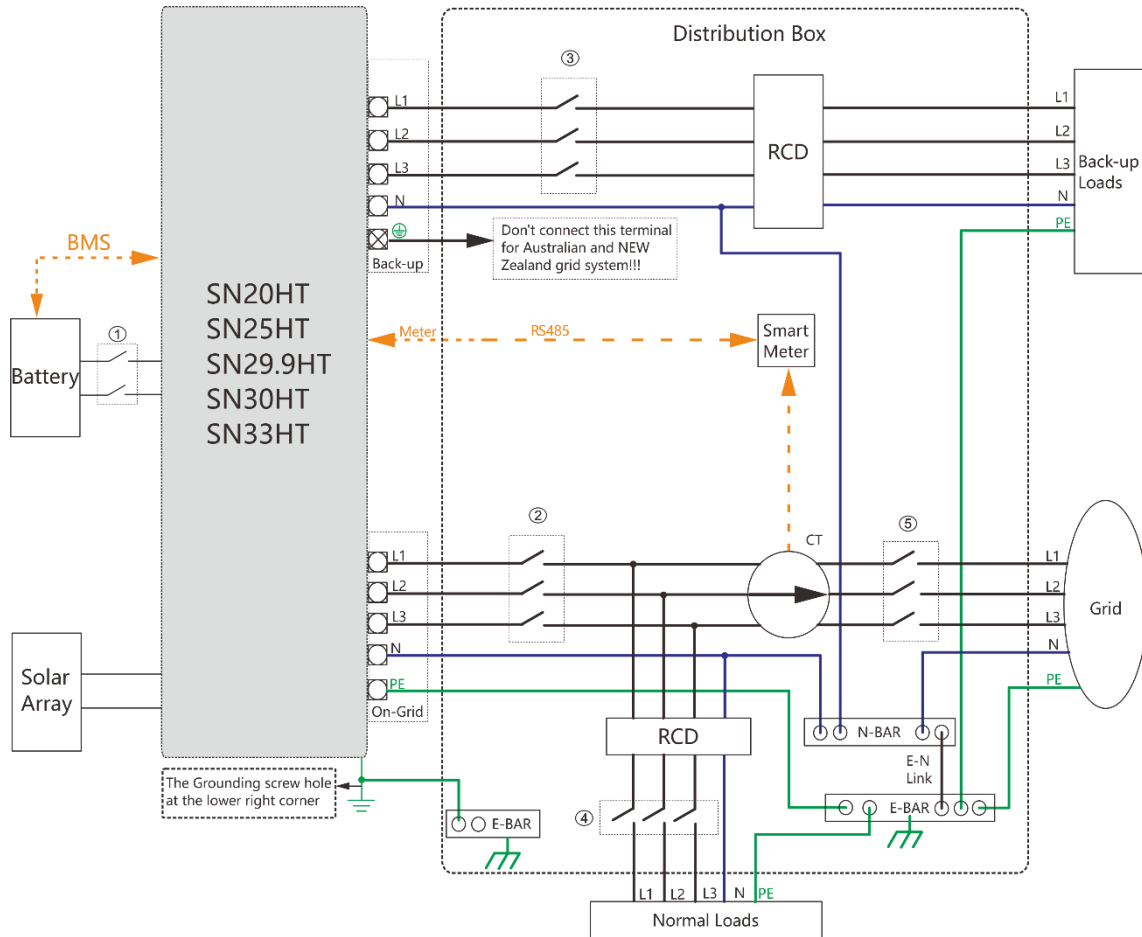

Figure B-1 Electrical system wiring diagram

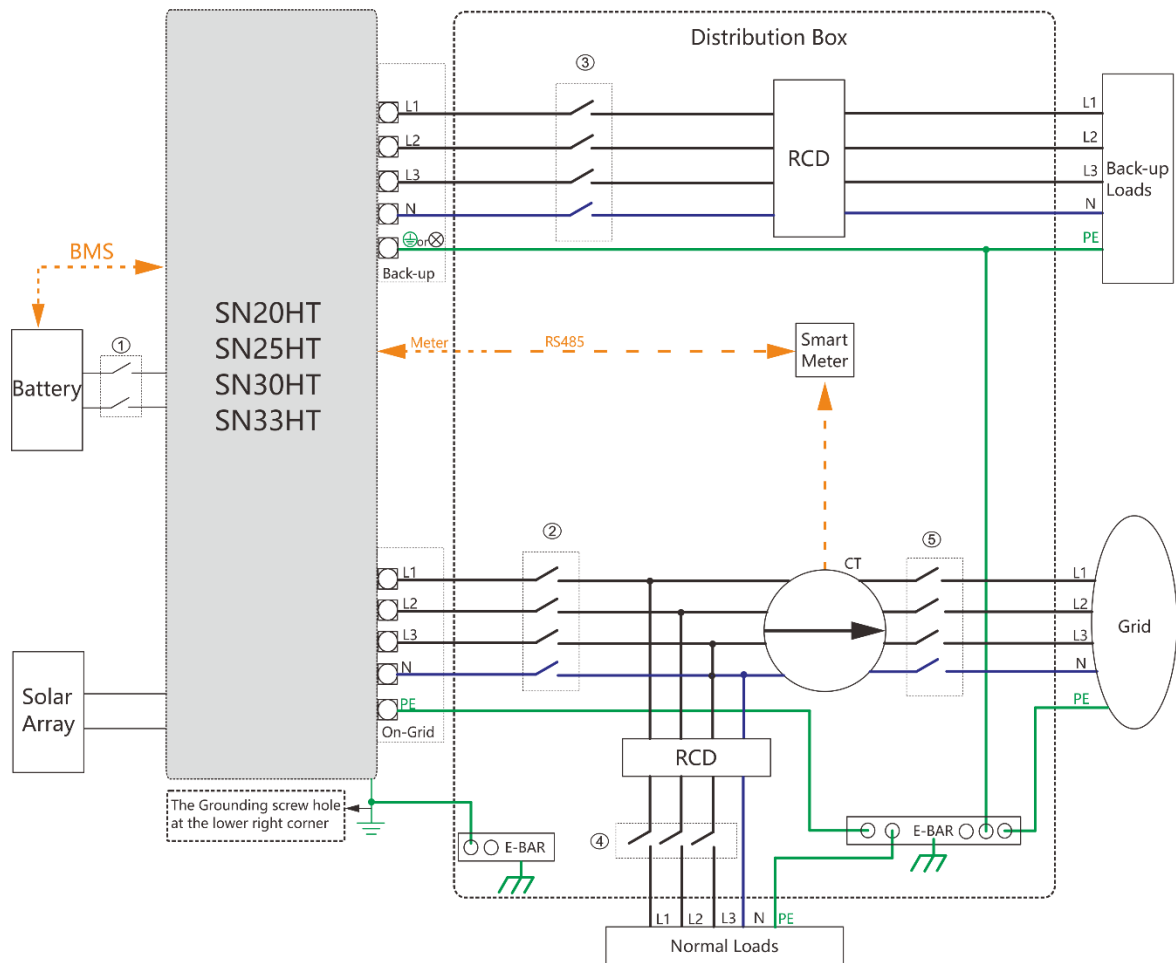

Figure B-2 Electrical system wiring diagram

This diagram is an example for an application in which neutral is separated from the PE in the distribution box.

For countries such as China, Germany, the Czech Republic, Italy, etc., please follow local wiring regulations!

Appendix C Stopping the Inverter



Warning

- After the inverter is completely powered off, there are still dangerous voltage hazards in the inverter! Wait for 30 minutes before operating the inverter!
-

Procedure

- Step 1 Issue a trip command to the inverter.
- Step 2 Disconnect the AC switch between the inverter and the grid.
- Step 3 Disconnect the DC and battery switches of the inverter.
- Step 4 Shut down the inverter and wait for the internal energy storage elements of the inverter to be discharged.

Appendix D Removing the Inverter



Warning

- After the inverter is completely powered off, there are still dangerous voltage hazards in the inverter! Wait for 30 minutes before operating the inverter!
- Before removing the inverter, disconnect both AC and DC connections.

Procedure

- Step 1 Issue a trip command to the inverter.
- Step 2 Disconnect the AC switch between the inverter and the grid.
- Step 3 Disconnect the DC and battery switches of the inverter.
- Step 4 Shut down the inverter and wait for the internal energy storage elements of the inverter to be discharged.
- Step 5 Disconnect all cables from the inverter, including communications cables, DC input power cables, BAT power cables, AC output power cables, and Ground cables.

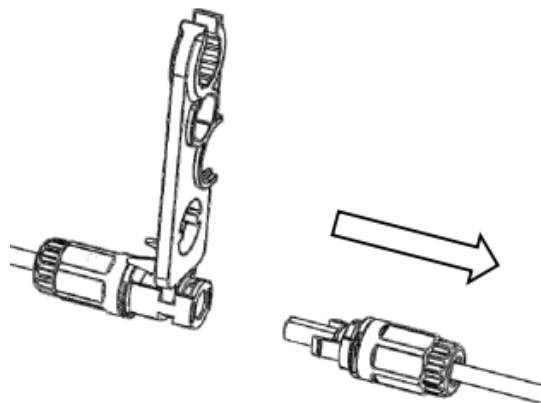

Figure D-1 Remove the connector

- Step 6 Remove the inverter from the mounting bracket.
- Step 7 Remove the mounting bracket.

Appendix E Disposal of the Inverter



Warning

The inverter is to be disposed of by the user. A discarded inverter is a kind of electronic waste containing hazardous substances, which will cause harm to the human body and the environment if not properly handled. Therefore, pay attention to the following when dealing with discarded inverters:

- Do not discard or pile up discarded inverters at will. Instead, hand them over to professional recycling organizations or departments in accordance with relevant laws and regulations to avoid secondary pollution.
 - Do not dismantle or repair the discarded inverter by yourself to avoid electric shock or exposure to harmful substances. It must be handled by professionals who wear protective equipment and take safety measures.
 - Do not mix discarded inverters with other wastes. Store them as separate categories, and indicate their properties and sources to facilitate recycling.
-

Appendix F After-sales Service Information

Sineng Electric Co., Ltd. provides a full range of technical support services for customers. Customers can contact the nearest Sineng local office or customer service center, or directly contact the HQ.

Sineng Electric Co., Ltd.

Address: No.6, Hehui Road, Huishan Economic Development Zone, Wuxi, China

Postal code: 214174

Service hotline: 400-928-6988