

EP-3125-HA-UD/10~35

MV Turnkey Solution for 1500V Utility PV Plant



More power generation

- Inverter Max. efficiency 99%, Euro efficiency 98.7%
- 1500Vdc PV system reduce power loss
- High DC/AC ratio up to 1.8

Low system cost

- Convenient for large block size PV plant
- Integrated MV transformer and switchgear
- Night SVG function optional

High reliability

- Capacitor life prediction technology
- Key components at front side, easy for maintenance
- Current sensor for each DC input, more reliable for monitoring and control

Grid friendly

- Adjustable reactive power
- Low harmonics and fast response for grid regulation

Circuit

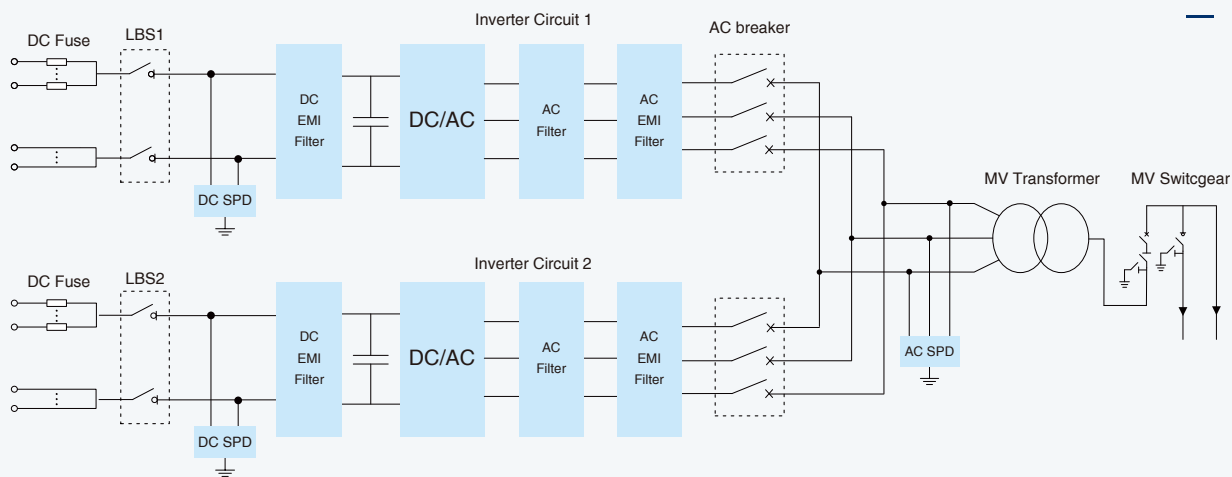

Input (DC)	EP-3125-HA-UD/10~35
Max. PV input voltage	1500V
Max. input current	4110A
MPP voltage range for nominal power	900~1300V
Number of MPPT trackers	2
Number of DC inputs	16~24
Output (AC)	EP-3125-HA-UD/10~35
Rated AC output power	3125kVA@50 C
Max. AC output power	3625kVA@25 C
AC voltage range	10~35kV
Rated grid frequency/range	50 Hz/ 45~55 Hz, 60Hz/ 55~65 Hz
Output current harmonic(at nominal power)	< 3 %
DC current injection	< 0.5% In
Power factor at nominal power/range	>0.99/ 0.8 lagging to 0.8 leading
Protection	EP-3125-HA-UD/10~35
DC input protection	Load break switch+fuse
AC output protection	Circuit breaker
AC MV output protection	Circuit breaker
Overvoltage protection	DC Type II / AC Type II
Leakage current monitoring	Yes
Grid monitoring/Ground fault monitoring	Yes/Yes
Insulation monitoring	Yes
Overheat protection	Yes
Night SVG function	Optional
Anti-PID function	Optional
Efficiency	EP-3125-HA-UD/10~35
Inverter max. efficiency	99.00%
Inverter EU efficiency	98.70%
Transformer	EP-3125-HA-UD/10~35
Transformer rated power	3125kVA
Transformer max. power	3625kVA
LV / MV Voltage	0.63/10~35kV
Transformer Vector	Dy11
Transformer cooling type	ONAN (Oil Natural Air Natural)
General Data	EP-3125-HA-UD/10~35
Weight	18t
Protection level	Inverter:IP65, Others:IP54
Auxiliary power supply	Standard: 5kVA, Optional: max. 40kVA
Temperature	-30~+ 60 C (>50 C derating)
Allowed humidity(non condensing)	0 - 95 %
Cooling method	Temperature controlled forced air cooling
Max.operating altitude	2000m(standard) / > 2000m (optional)
Display	Touch screen
Communication port	RS485/Ethernet, Optional: optical fiber